



1150C 1152C

VAPOR SOURCE MASS-FLO® CONTROLLERS

Many new processing techniques, such as MOMBE (CBE) for III-V compounds, silicon deposition using TEOS, and plasma polymerization are placing increased demands on mass flow control techniques. All of the above applications use source materials that are liquids or solids at room temperature and require heating to increase the vapor source pressure.

MKS Thermal Mass Flow Controllers (MFCs) have gained wide acceptance due to their proven use in many difficult control applications, and are widely used in traditional “bubbler systems” employed in the past and present to deliver these hard-to-handle source materials. However, thermal mass flow meters require a specific internal temperature profile for optimum operation. Thus, the elevated source temperature required to develop sufficient pressure for these devices to work often precludes their use without a carrier gas. This means another flow measurement technique must be used. Our extensive experience with precision pressure measurement instrumentation made the addition of a pressure measurement-based mass flow meter and controller a natural extension of this technology, and led to the development of the 1150 and 1152.

Features & Benefits

- Deliver source vapor without the need of a carrier gas system, for precise and repeatable vapor source delivery
- Wide operating temperature range (30°C to 150°C) for delivery of a variety of source materials
- Precise temperature control of source material, as needed in carrier gas systems, is not required
- Temperature output is provided to monitor the mechanical assembly's temperature, preventing condensation
- High level (0-5 VDC) output, which is proportional to mass flow of vapor, for indication of flow amount
- All-metal seal design eliminates contamination due to permeation of elastomeric seals

The 1150 and 1152 Vapor Source MFCs are pressure-based measurement and control systems designed to meter and control vapor from low vapor pressure liquid and solid sources directly, without the need of a carrier gas.

The 1150 and 1152 MFCs consist of a fixed flow element and either one (1150) or two (1152) capacitance manometers for flow measurement, with a proportioning solenoid control valve for flow control (U.S. Patent No. 4,679,585). The 1150 and 1152 have all components and associated circuitry contained within a compact temperature-controlled assembly with a temperature status LED and relay to indicate when temperature is in range. A temperature sensor and voltage output is available to indicate that the 1150/1152 controllers are at an elevated temperature to prevent vapor condensation within the mechanical assembly.

Extremely tight temperature control of the vapor source is not required with the 1150/1152, as the control loop will compensate for minor inlet pressure variations. The source material simply needs to be heated to a minimum temperature to develop a sufficient upstream pressure to push the vapor into the processing chamber at the desired flow rate, and which accommodates the pressure drop caused by system plumbing and the 1150/1152 controllers.

The 1150/1152 are capable of delivering vaporized liquid source materials such as: TEOS, DADBS, HMDS, TMCTS, TEAL, TEB, TEG, TEI, TMAP, TMB, TMG, TMI, TaCl₅, DMEAA, Ti[OCH(CH₃)₂]₄, TiCl₄, TIBAL, and TMP.

Mass-Flow Measurement Theory

The 1150 is based on viscous choked flow technology while the 1152 is based on viscous laminar flow. The equations describing choked flow through an orifice and laminar flow through a long tube are shown in Figure 1.

Figure 1, Equation 1 shows how the flow through a choked orifice is related to the pressure upstream of that orifice. An absolute pressure measurement before the orifice is required. Choked flow is achieved when the upstream pressure (P_1) is approximately twice the downstream pressure (P_2). This condition can limit the dynamic range of accurate measurement; however, the control range repeatability is not compromised. (Upon entering non-choked flow, mass flow becomes a function of the upstream and downstream pressure ratio times the upstream pressure.) Since the upstream pressure must be twice the downstream pressure, this system is best suited for applications in which processing system pressure is less than a few Torr.

Figure 1, Equation 2, allows a slightly more complex system since both upstream and downstream pressures of the flow elements must be monitored. Since the difference and sum of these pressures are required $[(P_1 - P_2) \times (P_1 + P_2)]$ to compute flow, circuitry for the measurement is also more advanced. The benefit of this

approach is the upstream pressures need only be slightly higher than downstream or process pressures, minimizing heating requirements of the source material and allowing use at higher system pressures.

MKS has developed the capability to computer-configure the 1150/1152 Vapor Source Flow Controllers best suited to a particular material, flow rate, and system pressure. Given the necessary information, a computer generated plot of flow rate versus voltage is easily obtained for the user.

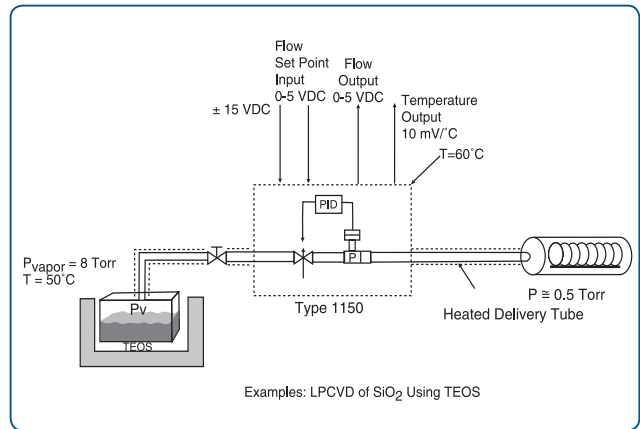

System Integration

In application, the 1150/1152 is placed downstream of the source material oven. Precise temperature control is not required as the unit control loop will compensate for inlet pressure variations. Delivery lines to or from the 1150/1152, or from the source oven to the process system, should be as short as possible and heated. A positive temperature gradient should be maintained on the components and plumbing from the source oven to the process chamber to prevent condensation. Condensation causes oscillation in flow stability or non-repeatability in film deposition rates. Similar problems may occur in bubbler systems if one is not careful.

The equations may be simply noted as follows:

Flow through a choked orifice

$$(1) \quad Q = CP_1$$

Flow through a laminar tube

$$(2) \quad Q = K(P_1^2 - P_2^2)$$

Where:

P_1 = upstream pressure

P_2 = downstream pressure

Q = mass flow

K, C = constants

Figure 1 — Gas Flow Measurement Equation



System Components

The critical pressure measurement in the 1150/1152 is made by the reliable Baratron® capacitance manometer (Figure 2). With the 1150, one sensor is used; with the 1152, two sensors are used. Components are assembled to the flow element body using nickel seals. The environment around the mechanical assembly of control valve, flow element, and sensor in the 1150 and 1152 is temperature controlled up to 100°C (temperature control to 150°C is available upon request). Above the mechanical assembly in the 1150/1152 is the pressure sensor signal conditioning and P.I.D. control loop circuitry. The valve driver output of the controller is sent to a solenoid-type proportioning valve upstream of the flow element to deliver the desired amount of gas flow to the process chamber.

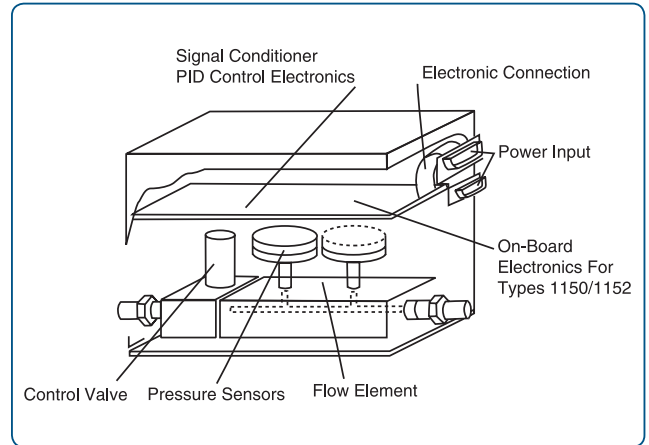
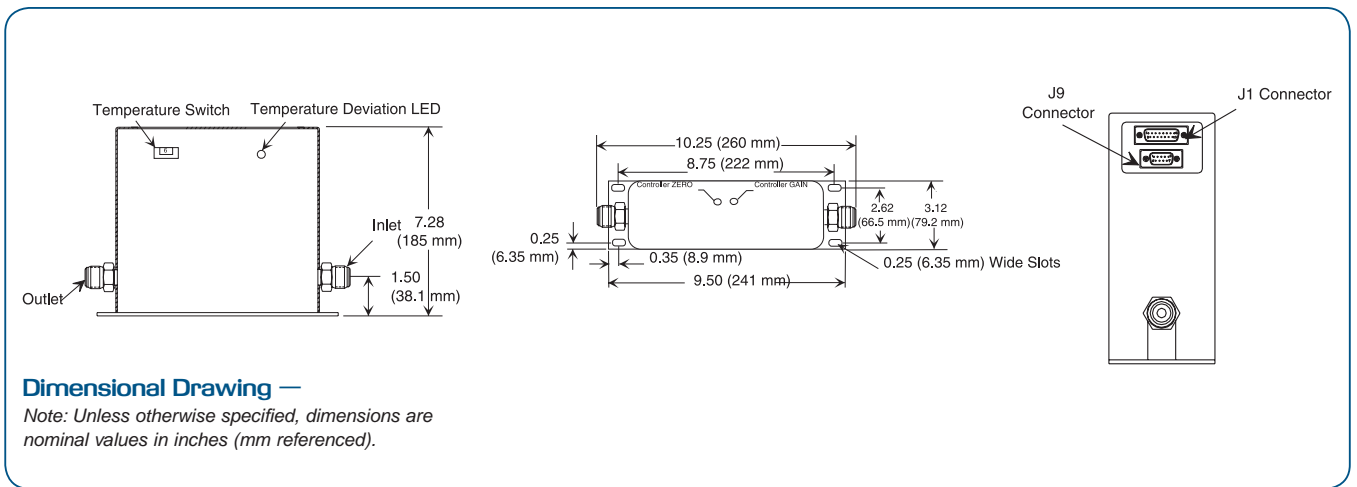

Figure 2 – Component Assembly

Accessories

Electrical requirements (power supply voltages, input command signal, and flow output signal) for the 1150/1152 have been tailored to match those of thermal MFCs so minimum work is necessary to integrate these flow controllers into a system's gas control panel. The 1150/1152 use ± 15 VDC for input power to the flow control electronics board, have a 0 to 5 VDC signal proportional to mass flow, and require a 0 to 5 VDC input for set point. Standard MKS electronic modules, such as the 647, 246 or 247, may be used with the 1150 and 1152 to form a complete system. Power for the 1150/1152 heaters can be obtained from MKS power supplies, e.g., 260PS-1 at 1.5 Amps and 260PS-3 at 3.5 Amps, or the power supplies capable of providing the required current to generate the specified control temperature.



Specifications and Ordering Information

Full Scale Ranges (N ₂ equivalent)	1 to 1000 sccm typical (dependent upon source material)
Control Range	5.0 to 100% of F.S.
Accuracy (including linearity and hysteresis)	±5.0% of F.S.
Repeatability	±0.2% of F.S.
Measurement Resolution	±0.1% of F.S.
Operating Temperature Range	
Standard	30°C to 100°C, adjustable
Optional	90°C to 150°C
Setting Time (to 100% of Full Scale)	1 second to within 2% of set point
Input Power Required	
Meter/Controller	±15 VDC (±2%) @ 0.28 Amps
Heater	±15 VDC @ 1.5 Amps (3 Amps with 90°C to 150°C option)
Set Point Signal	0-5 VDC from <20K Ω (Although DC input impedence of the set point circuit is high, we recommend a relatively low set point drive signal impedence (1000 Ω or less) for good noise immunity when the unit is used in high RFI or EMI environments.)
Output Flow Signal	0-5 VDC into >10K Ω
Temperature Output	10 mV/°C (0°C=0 VDC)
Relay Contact Ratings	2 Amps @ 28 VDC; 1 Amp @ 120 VAC resistive
Connector Type	
Signal	15-pin Type "D", RFI/EMI shielded
Heater	9-pin Type "D", RFI/EMI shielded
Maximum Line Pressure	35 psia
Leak Integrity	
To atmosphere	<1 x 10 ⁻⁹ scc/sec He
Through closed valve	<1% of F.S. or 1 sccm, whichever is greater (for specific applications, consult MKS Applications Engineering)
Process Wetted Materials	Inconel, 316 S.S., nickel
Mounting Position	Do not mount upside-down
Fittings	Swagelok® 8 VCR® male

Ordering Code Example: 1150C/1152C255	Code	Configuration
1150C & 1152C Mass-Flo Controllers	1150C/1152C	1150C
File Numbers to be provided by MKS Applications Engineering Group	255	255

MKS Instruments has developed computer design programs for the 1150 and 1152 that use various physical properties of the vapor source material to analyze the performance of those materials. The programs are a combination of vacuum system design routines used to determine pressure drops in upstream and downstream piping, and solutions to the generalized flow equations for viscous choked and laminar flow. This allows the determination of the best combination of source and MFC temperatures, pressure transducer(s) range, control valve size, and flow element to meet the particular customer requirement. These programs do not address the thermal stability or reactivity of the vapor phase material. MKS Instruments cannot be responsible for any reaction of the source material at the temperature required or any physical deposition of the source material or its reaction products in the flow controller. Please contact MKS Applications Engineering Group with information regarding your application for determination of an appropriate 1150/1152 system configuration.



MKS Instruments, Inc. Global Headquarters

2 Tech Drive, Suite 201
Andover, MA 01810
Tel: 978.645.5500
Tel: 800.227.8766 (in U.S.A.)
Web: www.mksinst.com

MKS Instruments, Inc. Flow Solutions

Six Shattuck Road
Andover, MA 01810
Tel: 978.975.2350