

Reactive

Gas

WWW.MKSINSTITUTE.COM

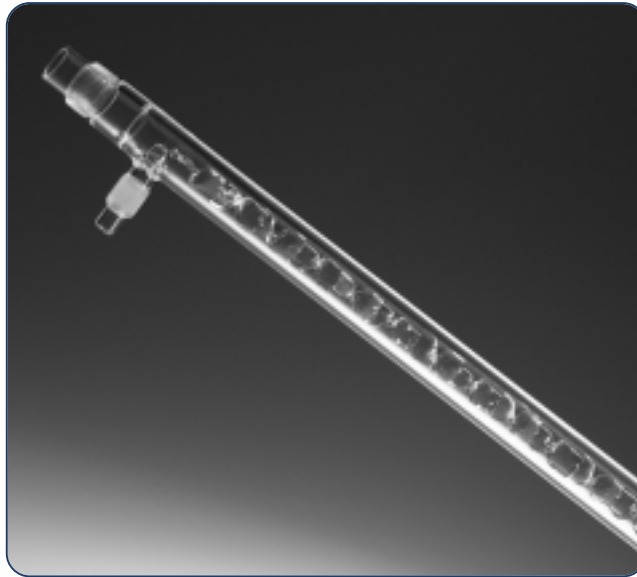

Model Types 8 and 12 are available in Quartz or PFA, Flaretek® or Pillar fittings are available

Static Mixer

A CONTACTOR FOR DISSOLVING OZONE GAS IN FLUIDS

The Static Mixer is designed to dissolve gases efficiently in fluids. Both gas and fluid are injected into the Static Mixer under pressure. A series of baffles converts the kinetic energy into turbulence, which results in improved mixing and solution. The fluids can be ultra pure water, sulphuric acid or, in the PFA version, water containing HF. Common applications include the solution of ozone gas in fluids for photoresist strip or for cleaning steps in semiconductor wet wafer processing.

Features & Benefits

Excellent Process Performance

- No moving parts, no contamination
- High efficiency mass transfer for maximum dissolved ozone
- Quartz and PFA/PTFE versions available to accommodate multiple chemistries
- Flaretek or Pillar compatible fittings available (Pillar only for PFA/PTFE version)

Low CoO

- Small size
- Reliable design
- No consumable parts



Performance

The following diagrams show two application examples. Through a single pass, 30mg/l can be reached. Steady state concentrations are achieved quickly in recirculation mode.

- Mixing of ozone in UPW (single pass)
- Mixing of ozone in hot sulfuric acid (recirculation)

Example of Setup

The mass transfer of ozone gas in the fluid correlates with the product of the fluid flow rate and the pressure loss over the Static Mixer.

Not all ozone can be dissolved within the fluid. If gas bubbles are undesirable in the bath, a de-bubbler (a vessel with a low flow velocity) should be installed behind the Static Mixer. The gas outlet of the de-bubbler contains ozone, which has to be destroyed properly before exhausting into the environment.

For practical reasons, the gas inlet of the Static Mixer should be pointing upwards to avoid fluid residues in the gas line.

The Static Mixer can be installed within the recirculation loop. It must then be installed downstream of the pump (to minimize possible cavitation problems).

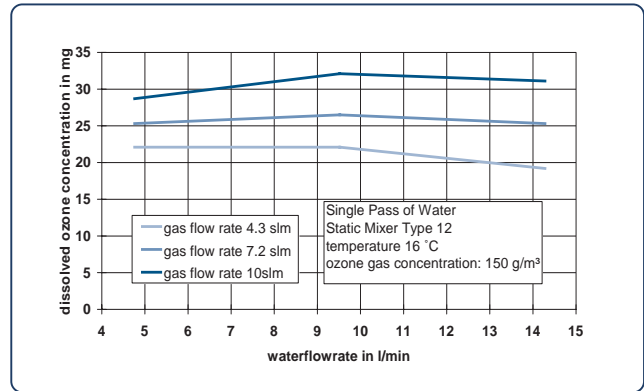

Figure 1 — Application of ozone in cold water, single pass

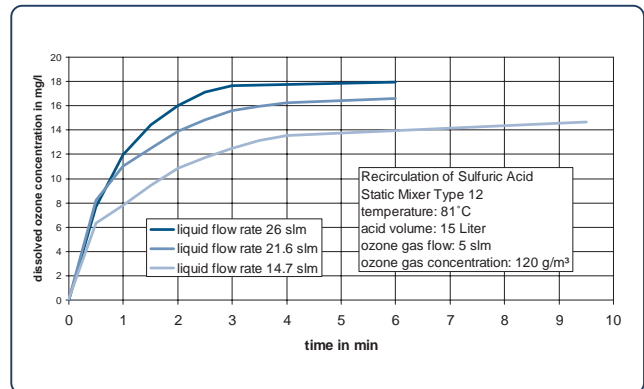

Figure 2 — Application of ozone gas in hot sulfuric acid, recirculation

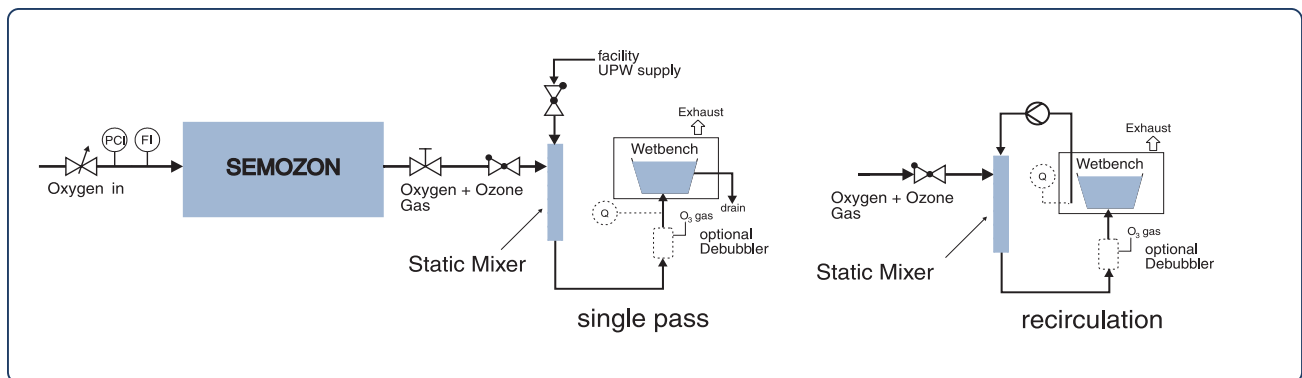

Figure 3 — Two typical installation examples with a SEMOZON™ ozone generator supplying a bath in a semiconductor wet bench



Specifications

	Static Mixer Type 8	Static Mixer Type 12
Fluid Flow Range	5 – 12 l/min recommended	10 – 25 l/min recommended
Gas Flow Range	Between 30% and 100% of the fluid flow (slm per l/min), 50% recommended	Between 30% and 100% of the fluid flow (slm per l/min), 50% recommended
Max. Operation Pressure	3.2 bar _{gauge} (46 psi _{gauge}) at 24°C (75°F) 1.5 bar _{gauge} (22 psi _{gauge}) at 130°C (266°F), PFA 1.0 bar _{gauge} (15 psi _{gauge}) at 130°C (266°F), Quartz	3.2 bar _{gauge} (46 psi _{gauge}) at 24°C (75°F) 1.5 bar _{gauge} (22 psi _{gauge}) at 130°C (266°F), PFA 1.0 bar _{gauge} (15 psi _{gauge}) at 130°C (266°F), Quartz
Fittings for the fluid phase	Flaretek compatible 1/2"	Flaretek compatible 3/4" Pillar 3/4" for PFA version available
Fittings for the gas phase	Flaretek compatible 3/8"	Flaretek compatible 3/8" Pillar 3/8" for PFA version available
Dimensions (see Dimensional Drawing and Ordering Information)		
Outer Diameter	Ø 20 mm	Ø 27 mm
Weight	185 g (Quartz version)	385 g (Quartz version) 325 g (PFA version)



Ordering Information

Static Mixer Type	Material	Fittings type	Dimensions		
			L	A	B
8 Quartz	Quartz	Flaretek compatible	339mm	67mm	50mm
12 Quartz	Quartz	Flaretek compatible	470mm	67mm	50mm
12 PFA Flaretek	PFA/PTFE	Flaretek	470mm	45mm	50mm
12 PFA Pillar	PFA/PTFE	Pillar	460mm	43mm	62mm

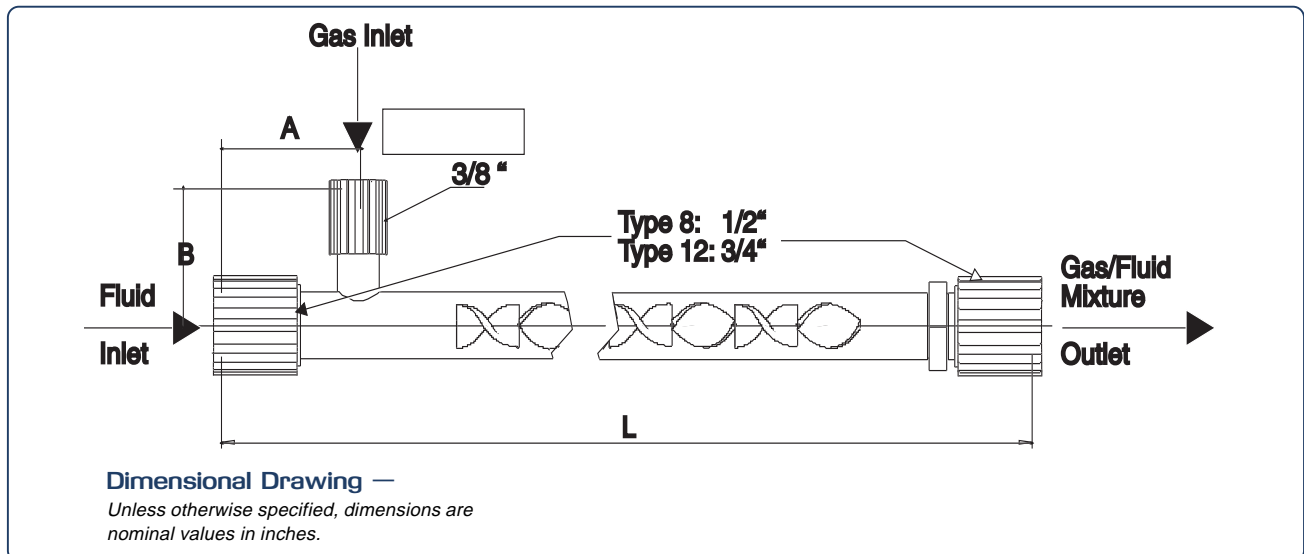

Global Headquarters

2 Tech Drive, Suite 201
 Andover, MA 01810
 Tel: 978.645.5500
 Tel: 800.227.8766 (in U.S.A.)
 Web: www.mksinst.com

MKS ASTeX GmbH

Wattstrasse 11-13
 D-13355 Berlin, Germany
 Tel: +49 30-464-0030