



DPC

DUAL-ZONE PRESSURE CONTROLLER

The Dual-Zone Pressure Controller (DPC) is a highly integrated closed-loop pressure control subsystem. It consists of an inlet pneumatic shut-off valve, two independent channels of pressure control with mass flow metering, and a vacuum outlet. Each pressure control channel consists of a pressure sensor, a control valve, and a mass flow meter, similar to the MKS Type 649 Pressure Controller with Integral Mass Flow Meter.

The DPC has been designed to reduce the overall cost of ownership of pressure control subsystems for backside wafer cooling, specifically for the latest two-zone electrostatic chucks (Figure 1).

Features & Benefits

Fully Integrated Solution

- Complete backside wafer cooling subsystem in a compact package
- Two independent channels of pressure control, each with mass flow metering
- Available with Analog or DeviceNet communications

Advanced Process Control

- Pressure measurement accuracy of $\pm 0.5\%$ of setpoint
- Tunable response for fast time to setpoint without overshoot
- Control stability of $\pm 0.1\%$ of setpoint

Smaller, Simpler, Lower Cost

- With single package integration, size and complexity are reduced greatly
- Less plumbing and cabling required
- Can be used in any application requiring independent pressure control and mass flow metering to two distinct volumes

Operation

As shown in Figure 2, the DPC consists of three sections – an inlet subassembly, a pressure control/flow metering subassembly, and an outlet subassembly. Pressurized helium gas is fed into the inlet subassembly. A pneumatic valve is then opened and the gas flow is split to two channels.

In the pressure control section, MKS Baratron® Capacitance Manometers measure pressure for each of the two zones. These pressures are compared to the pressure setpoints and an appropriate signal adjusts the position of the solenoid control valve to bring actual pressures into agreement with the setpoints. At the same time, mass flow is monitored on each channel by MKS Mass-Flo® meters calibrated for helium, which is the typical gas used for backside wafer cooling.

Downstream of the pressure control section, the outlet subassembly directs flow to the electrostatic chuck and provides a controlled “bleed” to vacuum through fixed orifices.



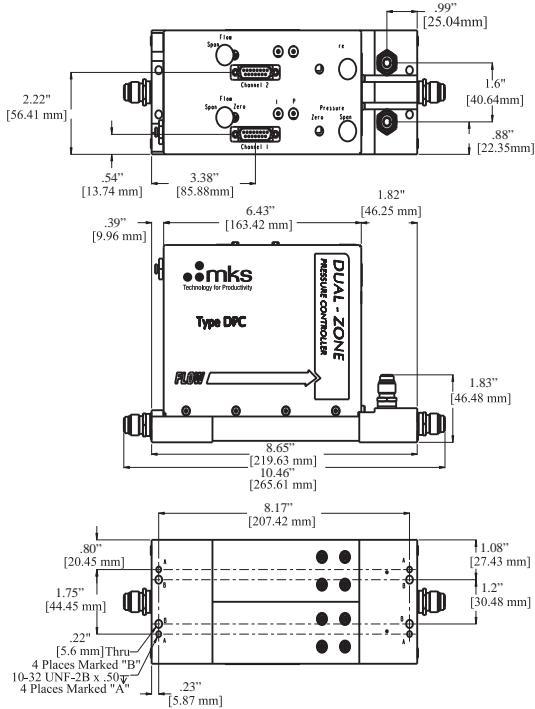

Analog Dimensional Drawing —
 Note: Unless otherwise specified, dimensions are nominal (ref.) values in inches.

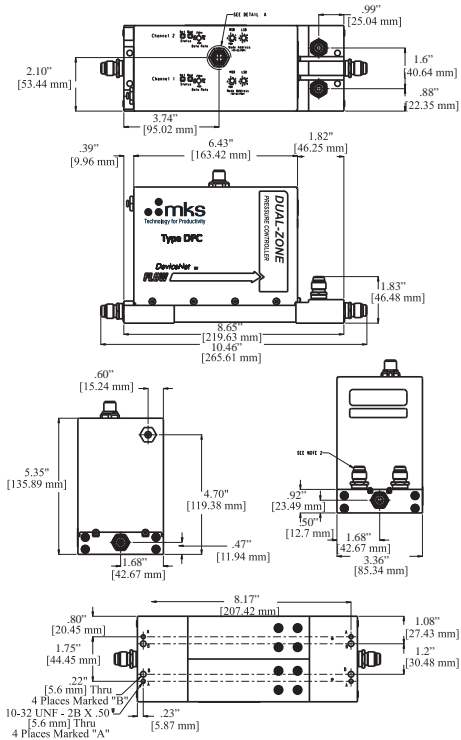

DeviceNet Dimensional Drawing —
 Note: Unless otherwise specified, dimensions are nominal (ref.) values in inches.

The purpose of the bleed is to insure that the pressure control system is not “dead-ended”. Since leak past the wafer is typically very low, the controlled bleed provides additional pressure relief for faster response to setpoint. Two different orifice sizes are used depending on the Full Scale range of the flow sensors. A smaller orifice size is used on units with 10 and 20 sccm FS flow sensors, and a larger orifice size is used on units with 50 and 100 sccm FS flow sensors. The smaller orifice size delivers 3.5 ± 1.5 sccm He at a control pressure of 9 Torr to the dump line. The larger orifice is sized to flow 13.0 ± 3.0 sccm He at a control pressure of 14 Torr to the dump line.

Communication and Control

Both analog and DeviceNet™ versions of the DPC are available. For the analog version, power is supplied at ± 15 VDC. The pressure setpoint and readout signals are 0-10 VDC and the flow sensor readout signal is 0-5 VDC. Ten-position gain and integral (P&I) term rotary switches provide a wide dynamic range for tuning pressure control performance. P&I switches are provided for each channel for independent tuning.

The digital DPC features digital control electronics and DeviceNet-compliant communication. The DPC DeviceNet profile for each channel basically adds an S-Analog Sensor object for mass flow sensing to the Process Control Valve object. Each channel has its own distinct MAC ID that is user-settable by two switches per DeviceNet specification. To optimize pressure control performance, users may adjust gain, integral and differential (P, I, D) constants for each channel using the DeviceNet communications protocol.

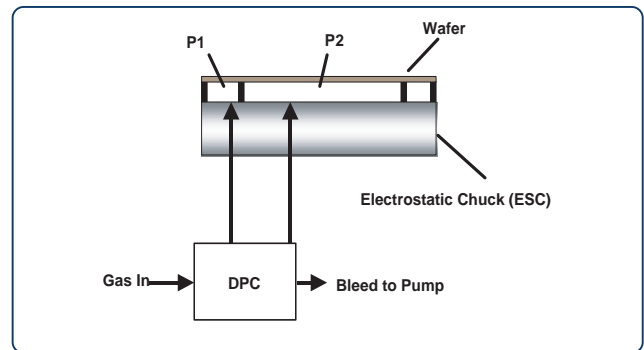

Figure 1 —
 Two Zone Backside Wafer Cooling

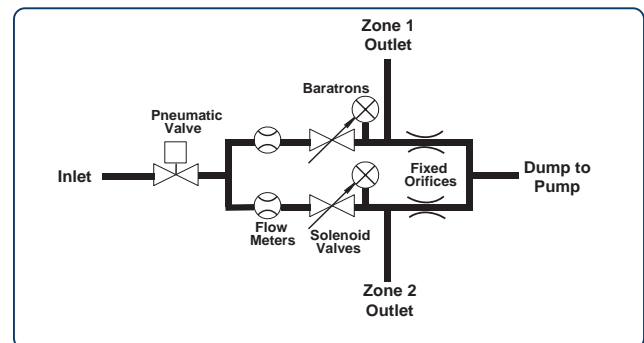

Figure 2 —
 DPC Functional Schematic



Specifications

Performance

Accuracy		
Pressure Transducer	±0.5% Reading ¹	
Mass-Flow Meter	±1.0% F.S. ²	
Leak Integrity		
Internal to external	<10 ⁻⁹ scc/sec He	
Through closed control valve	<1% F.S.	
Pressure Control		
Range	10-100% F.S.	
Stability at setpoint	≤0.1% setpoint	
Control Time to setpoint	≤2.0 seconds, typical	
Temperature Coefficient		
	<i>Pressure</i>	<i>Flow</i>
Zero	≤0.02% F.S./°C	≤0.05% F.S./°C
Span	≤0.04% Reading/°C	≤0.08% Reading/°C
Warm Up Time	1 hour	

Mechanical

Maximum Inlet Pressure	45 psia ³	
Dimensions (L x W x H)	10.46 in (incl. fittings) x 3.36 in x 5.35 in 26.56 cm (incl. fittings) x 8.53 cm x 13.59 cm	
Fittings	Swagelok® 4 VCR® male compatible	
Overpressure Limit	45 psia or 200% F.S., whichever is greater	
Full Scale Ranges		
Pressure	10, 20, 50, 100 Torr	
Flow	10, 20, 50, 100 sccm	
Pressure Transducer	Absolute pressure capacitance manometer	
Surface Finish	Ra ≤10 μinches, electropolished	
Weight	10.5 lbs. (4.8 Kg)	
Wetted Materials	316L Stainless Steel, Inconel®, Nickel, Elgiloy®, Viton®	

Electrical - Analog DPC

Input Power	±15 VDC ±5%, 500 mA, maximum during first five seconds at start up, 400 mA at steady state	
Electrical Connectors	15 pin D male (one per channel)	
Output Signals		
Flow	0 to 5 VDC	
Pressure	0 to 10 VDC	
Pressure Setpoint Input	0 to 10 VDC	
Control Adjustments		
Integral	10 positions (0 through 9)	
Proportional	10 positions (0 through 9)	
Maximum Cable Length	100 ft.	
CE Compliance		
Electromagnetic Compatibility ⁴	EMC Directive 2004/108/EC	

¹ Includes controller error, linearity, hysteresis and repeatability

² Includes linearity, hysteresis and repeatability

³ Consistent with the overpressure limit of the transducer

⁴ An overall metal braided shielded cable, properly grounded at both ends, is required during use.



Specifications (continued)

Electrical - DeviceNet DPC

Input Power	11-25 VDC
Electrical Connector	5-pin sealed microconnector with DeviceNet pin assignments
MAC ID's	2, one for each pressure control channel (4 MAC ID switches)
Baud Rate (user selectable)	125 Kbps (Network Length 500m) 250 Kbps (Network Length 250m) 500 Kbps (Network Length 100m) PGM (Programmable over the network)
Digital Functions	Read Pressure Read Flow Set Control Loop PID Select Units Set Zero
Visual Indicators	LED Network Status (green/red) LED Module Status (green/red)
CE Compliance	
Electromagnetic Compatibility ⁴	EMC Directive 2004/108/EC

Environmental

Ambient Operating Temperature Range	15° to 50°C (59° to 122°F)
Storage Temperature Range	-20° to 80°C (-4° to 176°F)
Storage Humidity Range	0 to 95% Relative Humidity, non-condensing

Ordering Information

Ordering Code Example: DPCA12T51CB00	Code	Configuration
Type Number DPC Dual-Zone Pressure Controller	DPCA	DPCA
Full Scale Pressure Range (XXT)		
10 Torr*	11T	12T
20 Torr	21T	
50 Torr	51T	
100 Torr	12T	
Full Scale Flow Rate (He equivalent) (YYC)		
10 sccm	11C	51C
20 sccm	21C	
50 sccm	51C	
100 sccm	12C	
Unit Configuration (Z)		
15 pin D Analog	B	B
5 pin DeviceNet Digital	6	
Firmware Revision (AA)		
Analog Version	00	00
DeviceNet Version (Current firmware revision is 1.82)	13	

*10 Torr/50 sccm combination not available - consult factory.



MKS Global Headquarters

2 Tech Drive, Suite 201
Andover, MA 01810

Tel: 978.645.5500
Tel: 800.227.8766 (in U.S.A.)
Web: www.mksinst.com

DPC - 2/10
© 2006 MKS Instruments, Inc.
All rights reserved.

Specifications are subject to change without notice.
Inconel® is a registered trademark of Inco Alloys International, Huntington, WV. Swagelok® and VCR® are registered trademarks of Swagelok Marketing Co., Solon, OH. DeviceNet™ is a trademark of the Open DeviceNet Vendor Association, Coral Springs, FL. Viton® is a registered trademark of E.I. DuPont Co., Inc., Wilmington, DE. Elgiloy® is a registered trademark of Elgiloy® Limited Partnership, Elgin, IL. Mass-Flo® and Baratron® are registered trademarks of MKS Instruments, Inc., Andover, MA.