

Reactive

Gas

WWW.MKSINST.COM



*SEMOTON AX8550
Ozone Delivery System*

SEMOTON[®] AX8550

STAND-ALONE OZONE DELIVERY SYSTEM FOR HIGH FLOW PROCESSES

THE SEMOTON AX8550 is designed for high flow, high concentration, ultra-clean ozone generation and delivery. The AX8550 is uniquely suited for ozone applications in semiconductor fabrication. Ozone is an environmentally friendly alternative to many chemical processes. It has a high redox potential, can be generated at the point of use and is easily converted back to oxygen. Typical ozone applications include TEOS/Ozone CVD, Ta₂O₅ CVD, photoresist strip, wafer cleaning, contaminant removal, surface conditioning, and oxide growth.

AX8550 Series systems may be configured with one or two SEMOTON AX8400 series ozone generators with a choice of common or independent, dual-channel gas flow control. Performance features include closed-loop concentration monitoring and control, status monitoring, interface to tool and back pressure control. The power distribution module incorporates overcurrent and ground fault protection. The cooling water distribution panel includes filter, pressure indication and flow control.

The AX8550 system is modular to provide maximum uptime and minimum complexity. All modules are housed in a vented 19-inch rack. Systems are S2-0302 and CE Compliant and are safety and performance interlocked for rack exhaust, water flow, water leak and open door/panels.

Features & Benefits

Performance

- Closed-loop concentration control for process consistency
- Configurable to optimize concentration to process requirements
- Ultra clean zone
- Real time status monitoring and tool interface

Clean, Safe Alternative to Conventional Chemical Processing

- High redox potential
- Can be generated at point of use
- Green chemical, easily converted back to oxygen

Low Cost of Ownership

- Reduced chemical consumption and disposal costs
- Supports single or dual process tools for maximum efficiency and minimum size
- Compact footprint

Proven Reliability

- MKS' patented, field proven ozone generating technology
- CE Mark and S2-0302 compliant



Specifications and Ordering Information

Maximum Number O₂ Generators	2
Number Independent Channels	2
Flow Control	Upstream
Gas Mixing	Internal
Gas Flow Control/Indication	O ₂ and N ₂ Rotameters (MFCs optional)
Ozone Pressure Control	Manual
Ozone Concentration Control	Open Loop or Closed Loop
Ozone Concentration Monitor	Standard (gas phase)
Maximum Ozone Output	
Maximum output (AX8407)	375 g/hr/channel
Max Weight (approximate)	340 kg (750 lbs)
Dimensions (L x W x H)	916 x 611 x 1559 mm (36 x 24 x 61.4 in)
Operating Range	
Maximum total flow	30 slm max/channel
Nominal delivery pressure	1.4 - 3.1. bar _{gauge} (20-45 psig)
Ambient temperature	10° - 40°C (50°-104°F)
Control Interface	PLC with digital and analog input/output modules
Facility Requirements	
Oxygen Gas	Grade 6 or better with less than 1 ppm water, hydrocarbons, and halocarbons, dew point ≤40°F
Nominal O₂ Inlet Pressure	4.1 bar _{gauge} (60 psig)
Nitrogen Gas	Grade 5 or better
Nominal N₂ inlet pressure	4.8 bar _{gauge} (70 psig)
Cooling Water	
Recommended flow/channel	9.5 L/min (2.5 gpm)
Temperature	17°-23°C (63°-73°F)
Power (50/60 Hz) Service Rating	200-230 V, 3Ø, 50A max
Compliance	
AX8550 Systems	SEMI S2-0302, CE Mark NRTL tested to UL and CSA standards

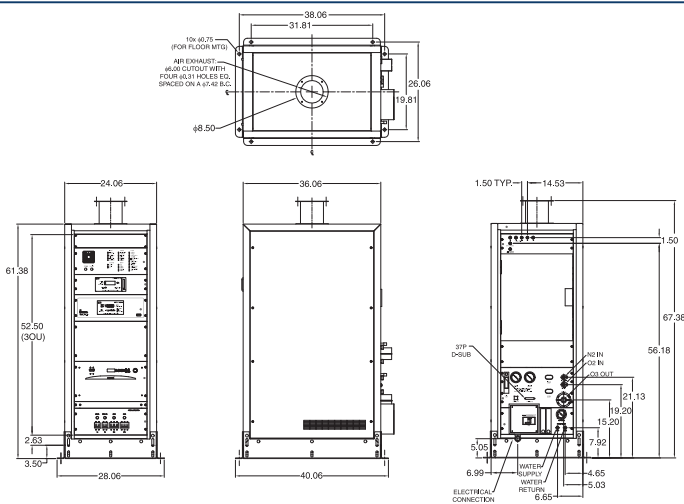

Dimensional Drawing —

Note: Unless otherwise specified, dimensions are nominal values in inches.

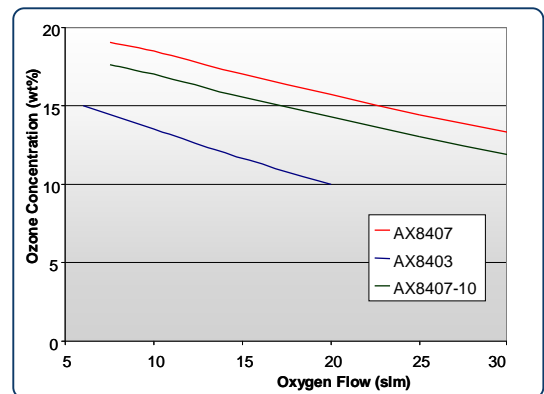

Performance Graph —

Typical System Performance with 8400 Series Generators



Global Headquarters

2 Tech Drive, Suite 201
Andover, MA 01810
Tel: 978.645.5500
Tel: 800.227.8766 (in USA)
Web: www.mksinst.com

MKS, ASTeX® GmbH

Wattstrasse 11-13
D-13355 Berlin, Germany
Tel: +49-30-464-0030