



## ASTRON<sup>®</sup>*i*

### TYPE AX7670 - REACTIVE GAS GENERATOR NO ARGON OPERATION, HIGHER FLOW, INCREASED IGNITION RANGE CAPABILITY

The ASTRON<sup>®</sup>*i* reactive gas generator is designed for increased flow capability and process flexibility. The ASTRON<sup>®</sup>*i* reactive gas generator eliminates the need for argon during processing, allows a choice of ignition gas compatible with existing process gases, and increases overall flow for decreased processing time and increased throughput.

Based on patented Low-Field-Toroidal plasma technology, the ASTRON<sup>®</sup>*i* reactive gas generator provides a broader range of operating pressures while maintaining a high input gas dissociation rate. The high reliability, field-proven design architecture combines the power source, control module, and plasma chamber. The result is a compact, lid-mountable unit, which is easy to integrate.

The primary application for the ASTRON<sup>®</sup>*i* reactive gas generator is as a remote source for reactive gas to clean undesired deposits from interior walls of CVD or FPD process chambers where greater process flexibility is required. By generating atomic fluorine that reacts with waste deposits in the chamber, new gases are formed that are readily scrubbed to minimize the environmental impact. In addition, the remote source reduces wear and tear on the process chamber compared to *in situ* RF methods.

### Features & Benefits

- No Argon required during operation
- Increased flow reduces chamber clean time
- Continuous operation (CW), not duty cycle limited, to support large chambers and/or long clean times
- Compatible with 200mm and 300mm chambers
- Choice of ignition gases for flexibility and lower CoO
- Compact, lid-mountable design, for easy integration
- High dissociation rate over broad pressure range for more robust operation with chamber clean hardware configurations



# Specifications and Ordering Information

## Gas Supply

Ignition  
Process

100% Ar for ignition only  
Up to 3.0 slm of  $NF_3$  (post ignition  $NF_3$  can be added and Ar removed)  
Contact MKS for alternate gas capability.

## Operating Pressure

$NF_3$  Operation

During ignition: 1 to 4 Torr @ 1 to 4 slm for Ar (pressure measured at ASTRON outlet)

## Reactant Output ( $NF_3$ Operation)

Post Ignition: 1 to 10 Torr post ignition up to 3 slm (pressure measured at ASTRON outlet)

>94% dissociation up to 2.5 slm, 3 to 10 Torr

>94% dissociation up to 3.0 slm, 5 to 10 Torr

## Duty Cycle

100%

## Wetted Materials

6061-T6 Aluminum hardcoat anodized, 6061-T6 Aluminum, Chemraz®, Alumina, Sapphire

## Control Interface

9 and 25 pin D connectors, opto-isolated I/O

## Inputs

On/Off

## Outputs

Ready

AC line

Plasma On

## Utilities

Power 180 to 228 VAC, 50/60 Hz, 30A, 3 phase

Cooling water 1.5 gpm, < 30°C

Ambient 40°C max.

## Physical

47 lb. (21.7 Kg)

16.7"L x 8.3"W x 10"H (417 x 207 x 250 mm nominal)

## Compliance

S2-2000 (includes S8, S10)

CE (EN61010, EN55011, EN61000-6-2)

NRTL (UL3101, CSA1010)

SEMI F47 Voltage Sag Immunity

## Ordering Information:

ASTRON®i Type AX7670 Reactive Gas Generator - Increased Ignition Range Capability No Argon Operation

Contact your local account representative for pricing, availability, and applications guidance.

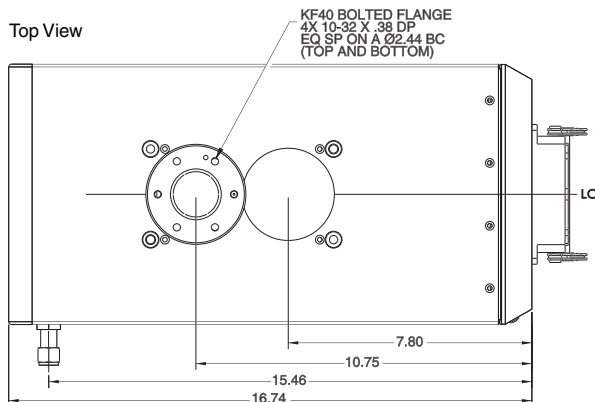

## Dimensional Drawing —

Note: Unless otherwise specified, dimensions are nominal values in inches.

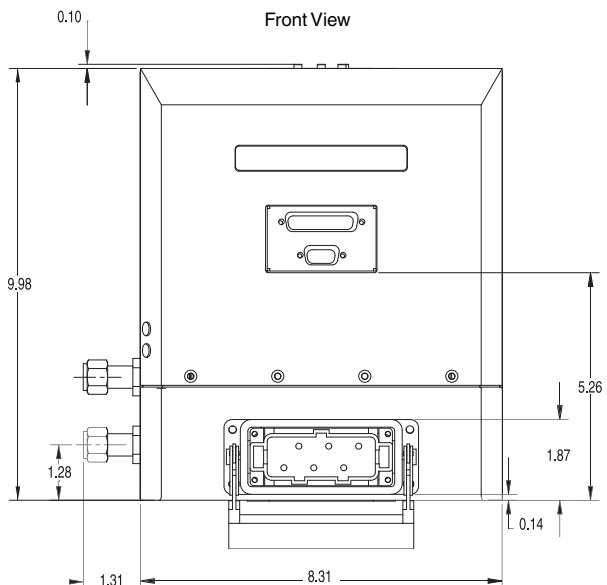

## Global Headquarters

2 Tech Drive, Suite 201  
Andover, MA 01810

Tel: 978.645.5500

Tel: 800.227.8766

Web: www.mksinst.com

## MKS ASTeX Products

90 Industrial Way  
Wilmington, MA 01887-4610

Tel: 978.284.4000

Web: www.mksinst.com