



HPS™ Products

HPS™ Products Series A900 Piezo / MicroPirani™ Vacuum Sensor System

Vacuum Transducers

Piezo

Piezo+

PiezoSteel™

PiezoSteel+™

MicroPirani™

DualTrans™

DualTrans+™

OPERATING AND MAINTENANCE MANUAL

Please Note:

MKS Instruments provides these documents as the latest version for the revision indicated. The material is subject to change without notice, and should be verified if used in a critical application.





HPS™ Products

HPS™ Products Series A900 Piezo / MicroPirani™ Vacuum Sensor System

Vacuum Transducers

Piezo

Piezo+

PiezoSteel™

PiezoSteel+™

MicroPirani™

DualTrans™

DualTrans+™

OPERATING AND MAINTENANCE MANUAL

Part A900- _____

Serial # _____

Please fill in these numbers and have them readily available when calling for service or additional information.

(The part number can be found on your packing slip, and both the part number and serial number are located on the bottom side of the housing.)

For more information or literature, contact:

5330 Sterling Dive
Boulder, CO 80301 USA

Phone: 303-449-9861
800-345-1967

Fax: 303-442-6880

©1999 MKS Instruments, Inc., HPS™ Products. All rights reserved.

Table of Contents

Table of Contents

Package Contents	1
Unpacking	1
General safety information	1
Symbols Used in this Manual	2
Safety Precautions	3
A900 features	4
Instrument installation	4
Transducer installation	4
Operation voltage	5
Front panel	5
Menu use	6
LED display	6
Rear panel	7
Transducer connectors	7
Power switch	7
Main voltage	7
Serial label	7
Analog out & Remote Zero connector	7
Setpoint relay connector	7
Turning the instrument on	8
Setpoint menu	8
Edit setpoint low value	8
Edit setpoint high value	9
Setpoint relay	9
Edit setpoint relay setting	9
Lock instrument menu	9
Lock procedure	9
Unlock procedure	10
Transducer Selection menu	10
View transducer selection	10
Change transducer selection	10
Gas Selection menu	10
View gas selection	10
Change gas selection	10
Adjustment menu	11
Zero and span	11
Reset and User adjustment	11
Pirani zero adjustment -	11
Pirani remote zero adjustment -	12
Piezo zero adjustment -	13
Piezo Auto Zero adjustment -	13
Pirani span adjustment -	13
Piezo span adjustment -	13
Linkpoint menu	14

View link selection	14
Change link selection	14
Change linkpoint value	14
Display unit menu	14
View display unit selection	14
Change display unit	14
Vacuum transducers	15
Piezo transducer	15
Piezo+ transducer	15
PiezoSteel™ transducer	16
PiezoSteel+™ transducer	16
MicroPirani™ transducer	16
DualTrans™ transducer	16
DualTrans+™ transducer	16
Transducer media compatibility	16
Outgassing	17
Explosive environments	17
MicroPirani™ voltage to pressure conversion -	17
Measuring range limits	18
Transducer dimensions, DN16KF vacuum connection	18
Dimensions	19
Specifications	19
Changing fuse	20
Connectors	20
Transducer extension cables	20
Pressure units	21
Warranty	22
Notes	23

Package Contents

Unpacking

Before unpacking your A900 Vacuum Sensor system, check all surfaces of the packing material for shipping damage. Please be sure that your A900 package contains these items:

- ◆ A900 controller
- ◆ Operation manual
- ◆ Power supply cord
- ◆ Spare fuse,
- ◆ Relay connector
- ◆ Mounting Kit



If any items are missing, please call MKS Customer Service at (800)345-1967 or (303)449-9861. Inspect for visible damage. If found, notify the carrier immediately.

General safety information

The safety instructions should always be followed during installation and operation of the A900 equipment. Otherwise, there is danger for electric shock and/or fire. Safety and installation instructions must be followed for continued compliance to low-voltage directive EN61010-1 (IEC1010-1). Pass safety information to all users.

Symbols Used in this Manual

The first two symbols below, that may be located on your A900, identify critical safety concerns. They are used throughout this manual to further define the safety concerns associated with the product.

The last two symbols identify other information in this manual that is essential or useful in achieving optimal performance from the A900.



CAUTION: Risk of electrical shock.



CAUTION: Refer to manual. Failure to read message could result in personal injury or serious damage to the equipment or both.



Failure to read message could result in damage to the equipment.



Calls attention to important procedures, practices, or conditions.

Safety Precautions



The A900 instrument must always be properly grounded. Be sure that the AC power line is grounded and use only the delivered 3 channel power cord or other approved power cord. Before connecting any other inputs, be sure to connect the AC power cord. Disconnect all other cables before removing the AC power cord.



If fuse change is required, before opening the apparatus, remove all other inputs and finally AC power line. Use only approved 5x20 mm. Fuses with proper rating.

Avoid using the A900 in presence of flammable gases or other explosive environments.

Make sure the AC power line is identical with the power supply specification on the A900 rear panel.

When installed in rack the AC power should be controlled from a central power supply.



If a transducer has to be returned to HPS™ Products for service, calibration or repair, proper decontamination must be carried out. A form that declares no radioactive, toxic, biological or other harmful contamination must be filled out.



The A900 complies to following European standards for CE marking.
EN 61010 (IEC 1010-1) , Low voltage directive.
EN 50081-1, EN50082-1 , Electromagnetic compatibility.

A900 features

- ◆ Wide range of configurations
- ◆ 2 transducer capability
- ◆ Single Setpoint with low and high limit for each transducer
- ◆ User adjustment of zero and span
- ◆ Keyboard lock
- ◆ Analog output
- ◆ 120 Vac or 230 Vac power supply
- ◆ DIN 43700, 96x96 robust aluminum housing

Instrument installation



Do not use or install the A900 where following conditions occur:

- ◆ Temperatures are lower than 0 °C or higher than 40 °C
- ◆ Corrosive or explosive gases occurs.
- ◆ Direct sunlight

For built-in applications the panel cut should be 92x92 mm. Mounting kit is include for the purpose of mounting the unit in a rack.

Transducer installation

All transducers for use with the A900 may be mounted horizontally or vertically. To avoid contamination of the transducer DO NOT install with the inlet flange facing upward. To obtain best performance the transducer should be mounted away from direct sunlight or other sources of temperature variations.

For transducer environment compatibility refer to transducer specifications on page 15.

If the instrument is delivered with only one transducer, it should be connected at the transducer 1 connector. DO NOT disconnect or connect transducer while the instrument is turned on. The instrument automatically detects and identify the connected transducer.

The protective plastic cap should be stored for maintenance purposes. Avoid damaging vacuum flange sealing surface and keep vacuum flange clean. Integrated transducer electronics allows the use of long cable runs up to 100 meters between transducer measuring point and the A900 instrument. Extension cables are available as accessories.

Operation voltage



The serial label specifies the AC power supply required. The instrument is delivered for 120 VAC or 230 VAC use. Make sure that the available AC supply voltage is identical with the power supply voltage on the serial label.

If the instrument is powered from AC voltage other than indicated, it's necessary to make an internal modification. Change of power supply setup should only be performed by qualified electrical or electronics maintenance personnel. For power supply setup procedure contact HPS™ Products. Only use the delivered 3 wire power cord or other approved power cord. The A900 power cord must always be properly grounded.



Front panel

The front panel is designed to provide a clear readout of the pressure measurement, setpoint relay status and transducer status. The current pressure unit is displayed to the right of the LED display.

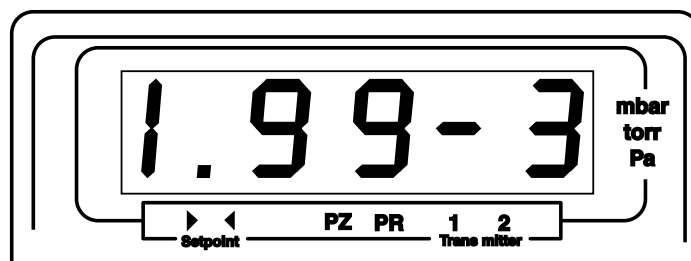
Indicator	Purpose
▶ red	Setpoint relay non active
◀ green	Setpoint relay active
PZ yellow	Piezo measurement (absolute gauge)
PR yellow	Pirani meas. (thermal conductivity gauge)
1 green	Transducer 1 measurement
2 green	Transducer 2 measurement
mbar red	millibar display unit (hPa)
torr red	torr display unit (mmHg)
Pa red	Pascal display unit



Menu use

All functions and settings are controlled from the front panel via menus. To select between menus use  or  key. The highlighted menu is entered by pressing  key.

Indicator	Purpose
LCK green	Lock keyboard / instrument
SET green	Setpoint settings
TR green	Transducer selection
ADJ green	Transducer software adjustment
GAS green	Transducer gas selections
LP green	Dual Sensor™ transducer linkpoint
DISP green	Display unit

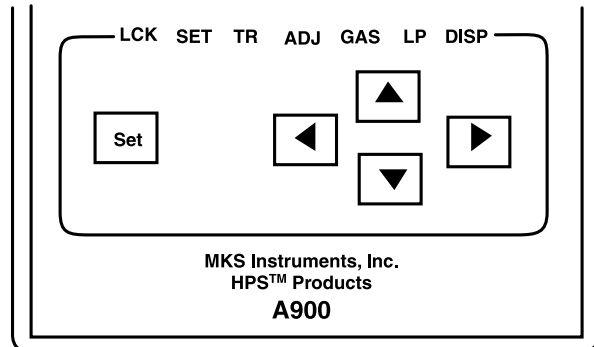

LED display

The 5 digit red LED display provides clear view of pressure measurement from long distance.

The display can either show measurements as numeric value or as float value of 3 digit mantissa and exponent.

Float display is only available when using MicroPirani™, DualTrans™ or DualTrans+™ transducer.

Float display (3.89×10^{-3})

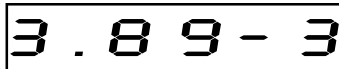

Numeric display (1013.2)

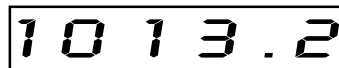

Rear panel

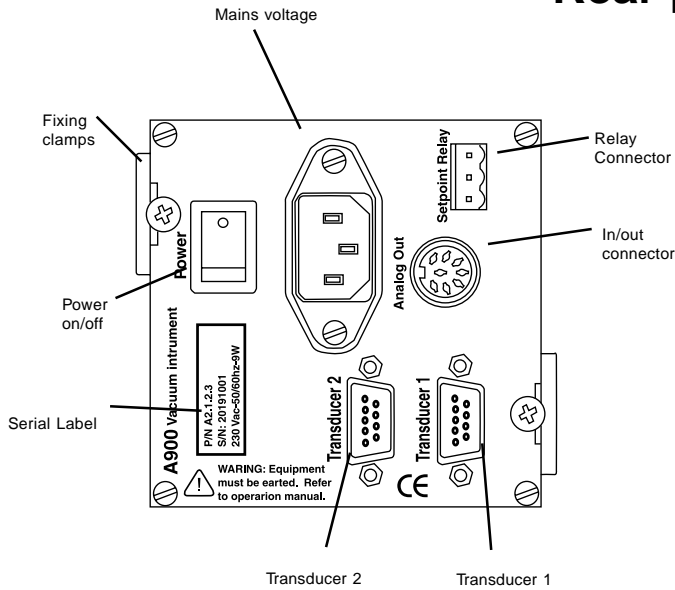

Transducer connectors

The transducers are connected at the rear-panel. If only one transducer is available it should be connected at the transducer 1 connector.

Power switch

Mains AC power on or off.

Main voltage

IEC connector is for AC power supply.

Serial label

The serial label is an individual identification number for the instrument. Furthermore AC voltage setup is specified at the serial label. Do not remove the serial label.

Analog out & Remote Zero connector

The analog output is the voltage provided by the transducer measuring electronics. If the analog output is shorted to ground or heavily loaded, the pressure readout will be affected.

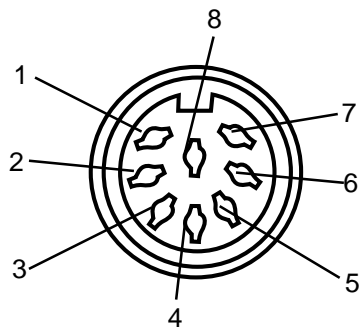

Analog output connector 8 pin DIN

1. Transducer 1 Piezo output (0 to 2 volt)
2. Transducer 1 MicroPirani™ output (0 to 10 volt)
3. Transducer 1 & 2 output -
4. Transducer 2 MicroPirani™ output (0 to 10 volt)
5. Ground
6. Remote Zero input -
7. Remote Zero input +
8. Transducer 2 Piezo output (0 to 2 volt)

Setpoint relay connector

The setpoint circuit operates a relay for external control purposes. The relay contacts are rated for 250 VAC/ 8A resistive load. Wire sized from 0.5 to 1.5 mm² can be mounted at the relay connector. The relay connector is, as standard, included with the A900 instrument.

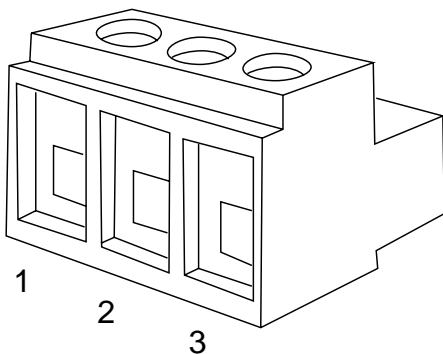

- | | |
|--------------------|---|
| 1. Normally Open | 2 |
| 2. Normally Closed | 3 |
| 3. Center contact | 1 |

Turning the instrument on

When turning the instrument on, the connected transmitter type is detected and displayed.

If the A900 is turned on without connection of a transducer the instrument will display an error message.

MicroPirani™

PirAn

Piezo / +, PiezoSteel™ /+

PIEZO

DualTrans™ / DualTran+™

dUALTR

Setpoint menu











LCK SET TR ADJ GAS LP DISP

The setpoint can be used to control a valve, pump or other process control. The setpoint has a low and high limit and controls a relay with switch-over contacts.

At the front panel a red or green arrow indicates whether the setpoint relay is active or non active.

To the right is shown an example of a control sequence where a vacuum pump is controlled.

Edit setpoint low value

1. Press  to enter setpoint menu
2. Press  unit 'Setpoint low' is displayed
3. Press  to show setpoint low value
4. Press  to change between float and numeric value (1)
5. Press  to edit setpoint low value
6. Press     to change value
7. Press  to store value and leave setpoint low edit

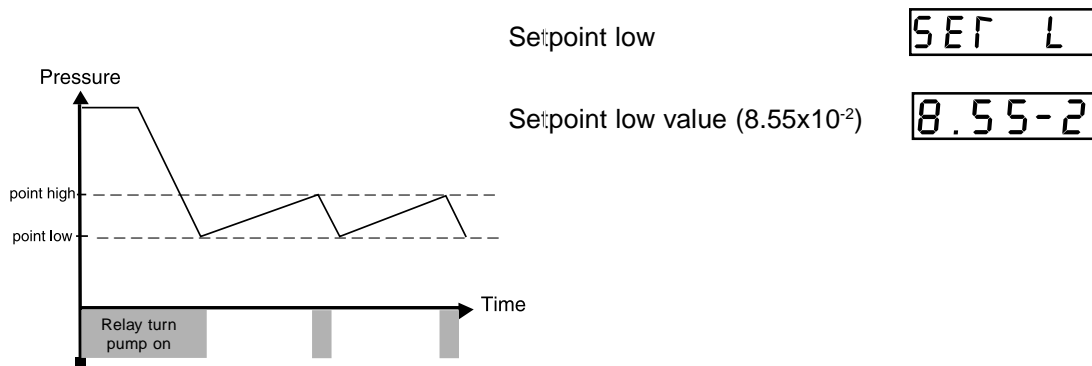











SEt H

Setpoint high

358.9

Setpoint high value (358.9)

Edit setpoint high value

1. Press  to enter setpoint menu
2. Press  unit 'Setpoint high' is displayed
3. Press  to show setpoint low value
4. Press  to change between float and numeric value (1)
5. Press  to edit setpoint low value
6. Press     to change value
7. Press  to store value and leave setpoint high edit

(1) Only valid when using DualTrans™ transducer.

Setpoint relay

The setpoint relay can be programmed to be active above setpoint limit or below. The relay includes both braking and closing contact, but the closing contact will also be closed if the instrument is turned off or in case of AC power dropout.

rELAY

Setpoint relay







ABOVE

Relay active above setpoint limit

bELoU

Relay active below setpoint limit

Edit setpoint relay setting

1. Press  to enter setpoint menu
2. Press  until 'Relay' is displayed
3. Press  to show relay setting
4. Press  to edit setpoint low value
5. Press   to change value
6. Press  to store value and leave edit

Lock instrument menu

LCK SET TR ADJ GAS LP DISP

In applications where the A900 controls an important process it could be fatal if the instrument was operated by unauthorized personal. To prevent this from happening the keyboard can be locked.







When the lock function is enabled, the instrument will perform measurement and control tasks, but it's impossible to enter the menus until the unlock procedure has been performed.

When the keyboard is locked the LCK light will flash to inform the user that the lock is activated.







LED Display:

LoCk Lock menu

Lock procedure

1. Press  to enter the lock menu
2. Press 
3. Press 
4. Press 
5. Press 
6. Press  keyboard lock activated and the instrument returns to measurement.

Unlock procedure

1. Press  to enter the lock menu
2. Press 
3. Press 
4. Press 
5. Press  to unlock the instrument
6. Press  to return to measurement

LED Displays:

A rectangular LED display showing the text "LoCh-" in a monospaced font.

Unlock confirmation

Transducer Selection menu LCK SET TR ADJ GAS LP DISP

Two transducers can be connected to the instrument. The transducer to be used is selected in the transducer selection menu. The transducer selection menu is only accessible when two transducers are connected to the instrument.

If user adjustment of zero and span has been performed, data is stored for each transducer.



A rectangular LED display showing the text "Tr 1" in a monospaced font.

Transducer 1





A rectangular LED display showing the text "Tr 2" in a monospaced font.

Transducer 2

View transducer selection

1. Press  to view current transducer selection.
2. Press  to return to measurement.

Change transducer selection

- Press  to change current transducer selection.
- Press  or  to change between transducer 1 and 2.
- Press  to select display transducer

Gas Selection menu LCK SET TR ADJ GAS LP DISP

The gas selection menu can only be accessed when using MicroPirani™, DualTrans™ or DualTrans+™ transducer. These transducers use measurement of thermal conductivity and consequently the readout will depend on gas or gas concentration. The A900 is calibrated for use with several common gases like atmospheric air, nitrogen, helium, argon and hydrogen. The gas selection menu allows the user to specify the measuring gas.

A rectangular LED display showing the text "Air" in a monospaced font.

Atmospheric air

A rectangular LED display showing the text "N2" in a monospaced font.

Nitrogen gas

A rectangular LED display showing the text "HE" in a monospaced font.

Helium gas



A rectangular LED display showing the text "Ar" in a monospaced font.

Argon gas





A rectangular LED display showing the text "H2" in a monospaced font.

Hydrogen gas

View gas selection

- Press  to view current gas selection.
- Press  to return to measurement.

Change gas selection

- Press  and  simultaneously to change gas selection.
- Press  or  to change between different gases.
- Press  to select displayed gas.

Adjustment menu LCK SET TR ADJ GAS LP DISP

All HPS™ A900 transducers are factory adjusted and recognized for excellent stability. However, the adjustment menu allows the user to make software adjustment of zero and span to compensate for minor drift. When using two transducers with the instrument each transducer must be adjusted, because data is stored for each transducer. All adjustment data are stored in permanent memory, and thereby not affected when power is turned off.

Zero and span

The zero point adjustment is an offset of the full measuring span. The span adjustment sets the full scale output at atmospheric pressure.

If both zero adjustment and a span adjustment is required the zero adjustment must be performed before making the span adjustment.

Reset and User adjustment

Two types of adjustments can be selected, the zero adjustment as well as the span adjustment. The reset adjustment is a general setup, that can be used if the user adjustment has been adjusted improperly.

The user adjustment allows the instrumentation software to compensate for minor differences of transducer zero and span.

If a new transducer is connected to the instrument, reset adjustment should be selected or for obtaining best performance the user adjustment procedure should be followed.

LED Displays:

2Er0

Zero menu

PirAn

Pirani zero menu

rESEr

Pirani zero reset adjustment

USER

Pirani zero user adjustment

PIE-5

Pressure < 1x10⁻⁵ mbar/torr ?

Pirani zero adjustment -

MicroPirani™, DualTrans™ and DualTrans+™ transducer

1. Press and simultaneously to enter adjustment menu.
2. Press until zero is displayed.
3. Press to enter zero menu
4. Press until pirani is displayed.
5. Press to enter pirani zero menu
6. Press to select pirani zero user adjustment
7. Evacuate the transducer to pressure lower than 1x10⁻⁵ mbar (torr) and press to perform zero adjustment.

Pirani remote zero adjustment -

MicroPirani™, DualTrans™ and DualTrans+™ transducer

The Remote Zero feature allows automatically zero adjustment of the pirani from an external source. This feature can be used in applications where another high or ultra high vacuum instruments like cold cathode, ionization, mass spectrometer or any other instrument able to measure a pressure lower than 1×10^{-5} mbar (torr) is available. To use the Remote Zero function a setpoint with external relay must be available at the high vacuum instrument.

The Remote Zero input is available at the analog output connector at the rear panel (refer to page 4 & 5)









- ◆ Connect the A900 Remote Zero input to HV (High Vacuum) instrument relay contact.
- ◆ Program the HV instrument to close relay contact at pressure below 8×10^{-6} mbar (torr).

The A900 instrument will now be automatically zero adjusted by external HV instrument, whenever pressure is lower than 8×10^{-6} mbar.

The instrument does not store zero adjustment made by the Remote Zero function. When the instrument is turned off the zero adjustment is lost, and when the instrument is turned on again it will use reset or user adjustment.

Piezo zero adjustment -

Piezo, Piezo+, PiezoSteel™, PiezoSteel+™, DualTrans™ and DualTrans+™ transducer

1. Press  and  simultaneously to enter adjustment menu.
2. Press  until zero is displayed.
3. Press  to enter zero menu
4. Press  until piezo is displayed.
5. Press  to enter piezo zero menu
6. Press  to select piezo zero user adjustment
7. Evacuate the transducer to pressure lower than 0.1 mbar (torr) and press  to perform zero adjustment.

LED Displays:



Zero menu



Piezo zero menu



Piezo zero reset adjustment



Piezo zero auto adjustment



Piezo zero user adjustment

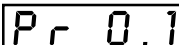

Pressure < 0.1 mbar/torr

LED Displays:

SPAn

Span menu

PirAn

Pirani span menu

rESEr

Pirani span reset adjustment

USER

Pirani span user adjustment

PI.0 3

Pressure=1.0x10+3 mbar/torr ?

SPAn

Span menu

PIE20

Piezo span menu

rESEr

Piezo span reset adjustment

USER

Piezo span user adjustment

1023.8

Pressure=1023.8 mbar ?

Piezo Auto Zero adjustment -











DualTrans™ and DualTrans+™ transducer

When using the DualTrans™ or the DualTrans+™ transducer the Piezo measuring circuit can be automatically zero adjusted by the MicroPirani measuring circuit.

When the Piezo Auto Zero function is selected the instrument will automatically zero adjust the Piezo whenever the pressure measured by the MicroPirani™ is lower 5x10-2 mbar.

Pirani span adjustment -

MicroPirani™, DualTrans™ and DualTrans+™ transducer













1. Press  and  simultaneously to enter the adjustment menu.
2. Press  until span is displayed.
3. Press  to enter span menu
4. Press  until pirani is displayed.
5. Press  to enter pirani span menu
6. Press  to select pirani span user adjustment
7. Connect the transducer to atmospheric pressure.
8. Press   to enter atmospheric pressure.
9. Press  enter to store pirani span adjustment.

Piezo span adjustment -

Piezo, Piezo+™, PiezoSteel™, PiezoSteel+™, DualTrans™ and DualTrans+™ transducer

In order to perform a Piezo span adjustment, the actual barometric pressure should be known. If a calibrated barometer is not available, the local airport have measurement of barometric sea level pressure. Altitude corrections must be made.

The Piezo sensor element is highly altitude sensitive, a altitude change of a few meters is measurable.

1. Press  and  simultaneously to enter the adjustment menu.
2. Press  until span is displayed.
3. Press  to enter span menu
4. Press  until piezo is displayed.
5. Press  to enter piezo span menu
6. Press  to select piezo span user adjustment
7. Connect the transducer to atmospheric pressure (950-1050 mbar).
8. Press     to enter atmospheric pressure.
9. Press  to store piezo span adjustment.



Linkpoint menu

LCK SET TR ADJ GAS LP DISP





The linkpoint menu can only be accessed when using the DualTrans™ or DualTrans+™ transducer. The DualTrans™ is a combination of a MicroPirani and a Piezo with two independent measuring circuits.

The Piezo measurement and MicroPirani™ measurement can be linked at a user defined linkpoint or only one of the circuits can be selected. The two measuring circuits use different measuring techniques which can result in minor differences when comparing the two measurements.







View link selection

1. Press  to view current linkpoint selection.
2. Press  to return to measurement.

Change link selection

1. Press  to change link selection.
2. Press  or  to change between link.
3. Press  to select displayed selection.

Change linkpoint value

1. Press  when link is displayed
2. Press     to change linkpoint value
3. Press  to store linkpoint value

LED Displays:

PirAn

MicroPirani™ measurement

PIEZO

Piezo measurement

Link

Piezo & Pirani linked

0010.0

Linkpoint value



Display unit menu

LCK SET TR ADJ GAS LP DISP

The A900 can display pressure readings in the 3 most common pressure units: mbar, torr and Pascal. The Pascal unit can only be selected when using a MicroPirani™ transmitter. The change of display units does not affect the analog output.

Already programmed setpoints and linkpoint will be converted to the selected unit.

View display unit selection

1. Press  to view current display unit selection.
2. Press  to return to measurement.

mbar

mbar display unit

Torr

torr display unit

PASCL

Pascal unit (MicroPirani™ only)

1000 mbar = 750.06 torr = 100,000 Pa

Vacuum transducers

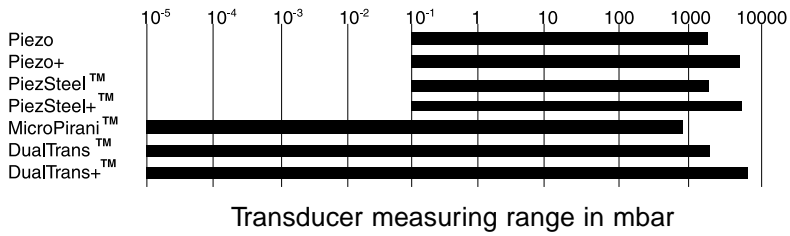

The transducers, for use with the A900, uses two different measuring technologies, absolute measurement and measurement of thermal conductivity.

Transducers based on absolute measurement measure the vacuum relative to a reference vacuum integrated in the sensor element. These transducers measure independent of gas or gas concentration and provide a linear output voltage.

Transducers based on a solid state MicroPirani

sensor element measures the thermal conductivity to the gas. The MicroPirani™ offers a wide measuring range with high accuracy and stability. The A900 can be equipped with any combination of transducers from the product range.

Absolute measurement

	Min	Typ	Max	Unit
Measuring	0.1		2000	mbar
Maximum pressure			2000	mbar
Output voltage	0.1		2000	mV
Measuring accuracy		1		mbar
Response time		10		ms
Dead volume		0.06		cm ³
Ambient temp. (working)	0		40	°C
Ambient temp. (storage)	-10		55	°C

Piezo transducer

The Piezo transducer is based on a solid state sensor for measuring the mechanical stress, due to pressure, in a silicon membrane.

It measures independent of gas or gas concentration and provides an output voltage directly proportional to applied pressure.

Absolute measurement

	Min	Typ	Max	Unit
Measuring	0.1		4000	mbar
Maximum pressure			4000	mbar
Output voltage	0.1		2000	mV
Measuring accuracy		2		mbar
Response time		10		ms
Dead volume		0.06		cm ³
Ambient temp. (working)	0		40	°C
Ambient temp. (storage)	-10		55	°C

Piezo+ transducer

The Piezo+ transducer is based on a solid state sensor for measuring the mechanical stress, due to pressure, of a silicon membrane.

It measures independent of gas or gas concentration and provides an output voltage directly proportional to applied pressure.

The Piezo+ combines vacuum measurement with measurement of pressure above atmospheric pressure in a single transducer.

Absolute measurement

	Min	Typ	Max	Unit
Measuring	0.1		2000	mbar
Maximum pressure			2000	mbar
Output voltage	0.1		2000	mV
Measuring accuracy		1		mbar
Response time		15		ms
Dead volume				cm ³
Ambient temp. (working)	0		40	°C
Ambient temp. (storage)	-10		55	°C

PiezoSteel™ transducer

The PiezoSteel™ transducer is designed for use in corrosive and aggressive environments. The solid state sensor element is protected by a stainless steel membrane. It can be exposed to all gases, vapor or liquid compatible with stainless steel 316 and viton

PiezoSteel+™ transducer

The PiezoSteel+™ transducer is designed for use in corrosive and aggressive environments. The solid state sensor element is protected by a stainless steel membrane. It can be exposed to all gases, vapor or liquid compatible with stainless steel 316 and viton.

MicroPirani™ transducer

The MicroPirani™ is based on a unique solid state sensor design for measuring thermal conductivity.

It covers a wide measuring range from atmospheric pressure down to 1×10^{-5} mbar.

The sensor design offers high measurement accuracy, a wide measuring range, very small dead volume and excellent stability to changes in ambient temperature.

DualTrans™ transducer

The DualTrans™ combines absolute and thermal conductivity measurement in one transducer. This combination provides a transducer with a very wide measuring of more than 8 decades from over pressure down to the high vacuum range of 1×10^{-5} mbar. The DualTrans™ contains two independent measuring circuits and provides two output signals.

DualTrans+™ transducer

The DualTrans+™ is based on the same sensor design as the standard DualTrans™, but has the benefit to measure pressure up to 4000 mbar.

In some vacuum applications, like gas filling systems, over pressure also occurs. In these applications the can DualTrans+™ allows pressure measurement up to 4000 mbar and thereby eliminate the need for a separate instrument for measuring over pressure.

Transducer media compatibility

All transducers for use with the A900, except the PiezoSteel™ / PiezoSteel+™, are designed for use in noncorrosive environments. Details and questions of media compatibility.

(1) Only transducers with aluminum flange.

Absolute measurement

	Min	Typ	Max	Unit
Measuring	0.1		2000	mbar
Maximum pressure			2000	mbar
Output voltage	0.1		2000	mV
Measuring accuracy		1		mbar
Response time		15		ms
Dead volume				cm ³
Ambient temp.(working)	0		40	°C
Ambient temp.(storage)	-10		55	°C

Thermal conductivity measurement

	Min	Typ	Max	Unit
Measuring range	1×10^{-5}		$1 \times 10^{+3}$	mbar
Maximum pressure			6000	mbar
Output voltage	0		10	V
Measuring accuracy		5		% of val
Response time		10		ms
Dead volume		0.6		cm ³
Ambient temp.(working)	0		40	°C
Ambient temp.(storage)	-10		55	°C

Thermal conductivity / absolute measurement

	Min	Typ	Max	Unit
Measuring range	1×10^{-5}		2000	mbar
Maximum pressure			2000	mbar
Output voltage MicroPirani	0		10	V
Output voltage Piezo			2	V
Accuracy MicroPirani		5		% of val
Accuracy Piezo		±1		mbar
Dead volume		0.65		cm ³
Ambient temp.(working)	0		40	°C
Ambient temp.(storage)	-10		55	°C

Thermal conductivity / absolute measurement

	Min	Typ	Max	Unit
Measuring range	1×10^{-5}		4000	mbar
Maximum pressure			4000	mbar
Output voltage MicroPirani	0		10	V
Output voltage Piezo	0		2	V
Accuracy MicroPirani		5		% of val
Accuracy Piezo		±2		mbar
Dead volume		0.65		cm ³
Ambient temp.(working)	0		40	°C
Ambient temp.(storage)	-10		55	°C

Table. 1 Exposed materials for different transducers.

	Piezo +/-	PiezoSteel +/-	MicroPirani	DualTrans +/-
Aluminum	*		*	*
Nickel (1)	*		*	*
Stainless steel	*	*	*	*
Gold			*	*
Viton	*	*	*	*
Plastic				*
Epoxy resin			*	*
Silicon			*	*
SiO ₂			*	*
Si ₃ N ₄			*	*

Outgassing

The use of solid state micro sensor technology exposes only a small amount of sensor material to the vacuum, thereby reducing the outgassing rate. Furthermore, the internal volume, commonly referred as dead volume, is significantly smaller compared to competitive gauges.

Explosive environments **WARNING**

Special precautions must be taken if any of the A900 transducers are used in applications where explosive gases are present. Contact HPS™ Products for instructions of use in these applications.

MicroPirani™ voltage to pressure conversion -

MicroPirani™, DualTrans™ and DualTrans+™ transducer

The MicroPirani™ measuring circuit provides a 0-10 volt output signal. The signal is nonlinear, but can easily be converted to pressure by use a 5 parameter analytic expression.

The MicroPirani™ is based on measurement of thermal conductivity measurement of the gas and consequently the pressure reading will depend on the actual gas. Different constants for each type of gas must be used.

V = Output voltage , P = Pressure in mbar

$$P = \frac{1}{C_0 + 1/ (C_1 V + C_2 V^2 + C_3 V^3 + C_6 V^6)}$$

CONSTANTS	Atm.air(1)	Nitrogen	Helium	Argon	Hydrogen
C0	-0.0278168	-0.03415668	0.00511812	-0.03535520	0.01035371
C1	0.1371869	0.13590410	0.17540366	0.20465318	0.10575009
C2	0.0602274	0.05873713	0.06735233	0.09100472	0.04184771
C3	0.0148662	0.01520440	0.00683732	0.02821050	0.00430022
C6	0.0000121	0.00000621	0.00000262	0.00001777	0.00000184

(1) Constants for atmospheric air is given at 55% humidity

Measuring range limits

In pure helium environments the upper measuring range is limited to approximate 20 mbar, because the measuring electronics saturates. For hydrogen the upper measuring range is limited to 12 mbar.

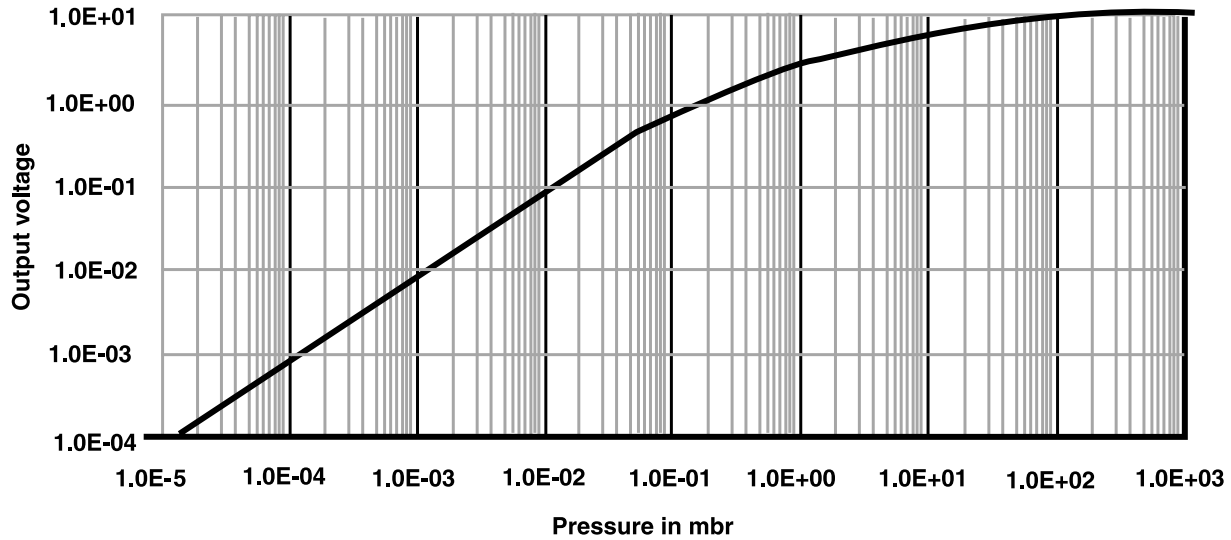

MicroPirani™ output voltage for nitrogen vs. pressure in mbar

Transducer dimensions, DN16KF vacuum connection

Transducer dimensions showed to the right are only for a transducer with DN16KF vacuum connection. DN16CF and ½ inch vacuum connection is also available for some of the transducers.

Dimensions in mm.

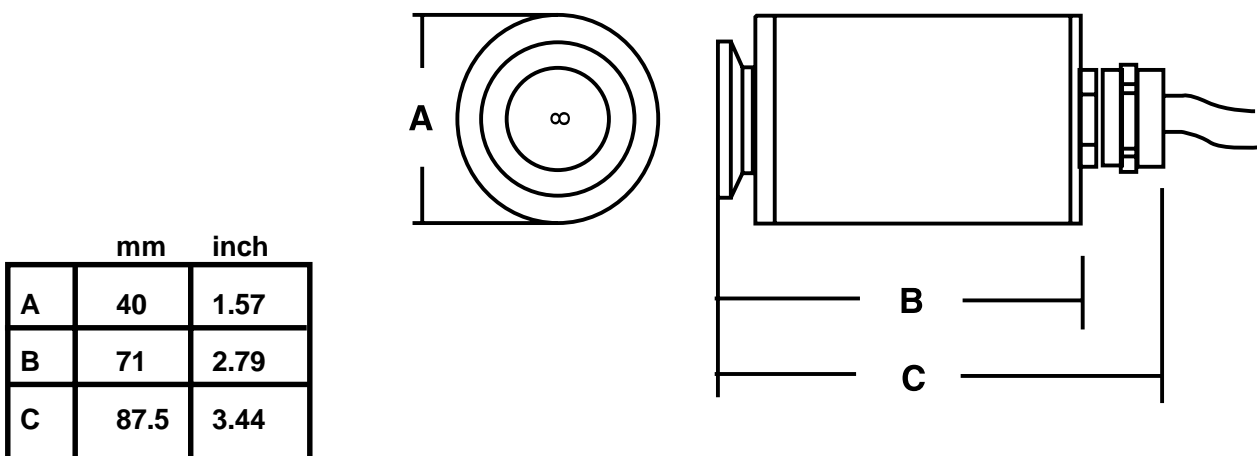

Specifications

Parameter	Min	Typ	Max	Unit
Mains supply voltage (230 V-setup)	198	230	242	V-
Mains supply voltage (120 V-setup)	90	120	130	V-
Frequency	50		60	Hz
Power consumption			9	W
Mains Fuse, 05x20 mm. (230 V-setup)		63		mA(slow)
Mains Fuse, 05x20 mm. (120 V-setup)		125		mA(slow)
Ambient temperature (working)	0		40	°C
Ambient temperature (storage)	-10		50	°C
Humidity	0		90	%rel.
Setpoint relay contact voltage			250	V-
Setpoint relay contact current ⁽¹⁾			8	A
Weight		1.0		Kg.

(1) Relay contact current is for resistive load. For non-resistive load use below graph to find reduction factor.

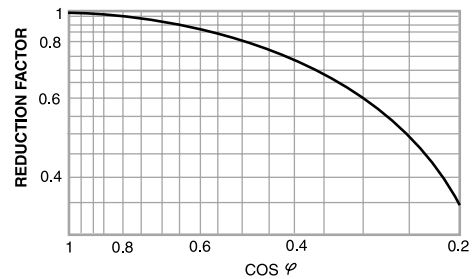

Dimensions

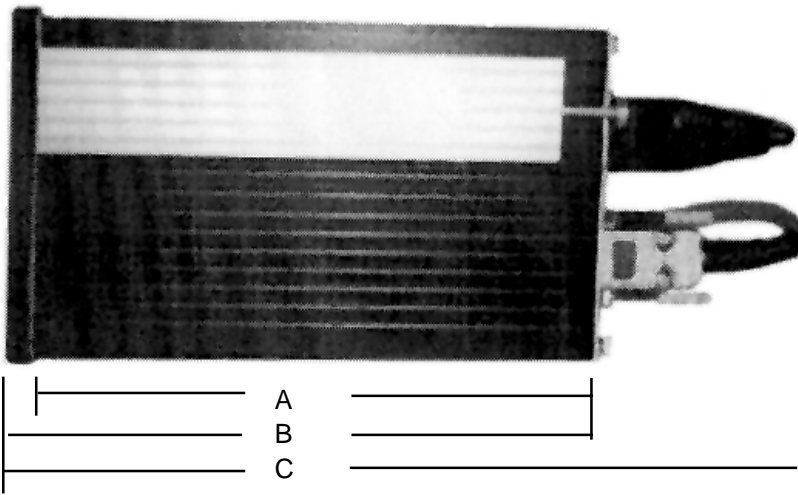

	mm	inch
A	157	6.181
B	165	6.496
C	237	9.252

Changing fuse



The A900 contains a mains fuse protection. The fuse will blow if the instrument is supplied with higher voltage than specified or in case of instrument malfunction

1. Turn the instrument off and remove all connectors and finally remove the power line.
2. Remove the 4 screws at the rear panel.
3. Softly insert a screwdriver between the rear panel and the instrument case and easily pull out until the rear panel is loose.
4. Change the fuse at the fuse holder with only approved fuses with proper rating.
5. Assemble the instrument again.

If the fuse blows again shortly after change, the instrument has most likely a malfunction and should be returned to HPS™ Products for repair.

230 Vac setup

63mA T, 250 V, ø5x20 mm

120 Vac setup

120mA T, 250 V, ø5x20 mm

◆ Connectors

Product description

Order code

Setpoint relay connector
Analog output connector

100010757
100010754

◆ Transducer extension cables

Cable runs up to 300 ft. are possible between the A900 and the transducer.

Product description

Order code

Transducer extension cable 10 ft.
Transducer extension cable 25 ft.
Transducer extension cable 50 ft.

103170006SH
103170007SH
103170008SH

Pressure units

The Standard International (SI) pressure unit is Pascal (Pa), but millibar (mbar) is still the most common unit in the European vacuum community. The Torr unit is widely used in the U.S. and Asia.

1 Pa is 1 newton of force per square meter

100 Pa = 1 hPa = 1 mbar = 0.75006 torr

	mbar	torr	kPa	Pa	PSI	cmH₂O	in.H₂O
mbar	1	0.75006	0.1	100	1.450x10 ⁻²	1.01973	0.40147
torr	1.3332	1	0.13332	133.32	1.9337x10 ⁻²	1.3595	0.53525
kPa	10.000	7.5006	1	1000	0.14504	10.1973	4.0147
Pa	1x10 ⁻²	7.5006x10 ⁻³	1x10 ⁻³	1	1.45x10 ⁻⁴	1.01973x10 ⁻²	4.0147x10 ⁻³
PSI	68.947	51.715	6.8947	6894.7	1	70.308	27.68
cm H₂O	0.9806	0.7355	9.806x10 ⁻²	98.06	1.42237x10 ⁻²	1	0.3937
in. H₂O	2.491	1.8683	0.2491	0.2491	3.6127x10 ⁻²	2.54	1

PSI - pound per square inch , cm H₂O - at 4 oC , In H₂O - at 39 oF

Warranty

Extent of the Warranty

MKS Instruments, Inc., HPS™ Products Inc., warrants the HPS™ Series A900 Vacuum Transducer and its accessories to be free from defects in materials and workmanship for one (1) year from the date of shipment by HPS™ or authorized representative to the original purchaser (PURCHASER). Any product or parts of the product repaired or replaced by HPS™ under this warranty are warranted only for the remaining unexpired part of its one (1) year original warranty period. After expiration of the applicable warranty period, the PURCHASER shall be charged HPS™ current prices for parts and labor, plus any transportation for any repairs or replacement.

ALL EXPRESS AND IMPLIED WARRANTIES, INCLUDING THE IMPLIED WARRANTIES OF MERCHANTABILITY AND FITNESS FOR A PARTICULAR PURPOSE, ARE LIMITED TO THE WARRANTY PERIOD. NO WARRANTIES, EXPRESS OR IMPLIED, WILL APPLY AFTER THIS PERIOD.

Warranty Service

The obligations of HPS™ under this warranty shall be at its option: (1) to repair, replace, or adjust the product so that it meets applicable product specifications published by HPS™ or (2) to refund the purchase price.

What Is Not Covered

The product is subject to above terms only if located in the country of the seller from whom the product was purchased. The above warranties do not apply to:

- I. Damages or malfunctions due to failure to provide reasonable and necessary maintenance in accordance with HPS™ operating instructions.
- II. Damages or malfunctions due to chemical or electrolytic influences or use of the product in working environments outside the specification.
- III. Fuses and all expendable items which by their nature or limited lifetime may not function for a year. If such items fail to give reasonable service for a reasonable period of time within the warranty period of the product; they will, at the option of HPS™, be repaired or replaced.
- IV. Defects or damages caused by modifications and repairs effected by the original PURCHASER or third parties not authorized in the manual.

Condition of Returned Products

HPS™ will not accept for repair, replacement, or credit any product which is asserted to be defective by the PURCHASER, or any product for which paid or unpaid service is desired, if the product is contaminated with potentially corrosive, reactive, harmful, or radioactive materials, gases, or chemicals.

When products are used with toxic chemicals, or in an atmosphere that is dangerous to the health of humans, or is environmentally unsafe, it is the responsibility of the PURCHASER to have the product cleaned by an independent agency skilled and approved in the handling and cleaning of contaminated materials before the product will be accepted by HPS™ for repair and/or replacement.

In the course of implementing this policy, HPS™ Customer Service Personnel may inquire of the PURCHASER whether the product has been contaminated with or exposed to potentially corrosive, reactive, harmful, or radioactive materials, gases, or chemicals when the PURCHASER requests a return authorization. Notwithstanding such inquiries, it is the responsibility of the PURCHASER to ensure that no products are returned to HPS™ which have been contaminated in the aforementioned manner.

Other Rights and Remedies

- I. These remedies are exclusive. HPS™ SHALL NOT BE LIABLE FOR CONSEQUENTIAL DAMAGES, FOR ANTICIPATED OR LOST PROFITS, INCIDENTAL DAMAGES OR LOSS OF TIME, OR OTHER LOSSES INCURRED BY THE PURCHASER OR BY ANY THIRD PARTY IN CONNECTION WITH THE PRODUCT COVERED BY THIS WARRANTY, OR OTHERWISE. Some states do not allow exclusion or limitation of incidental or consequential damage or do not allow the limitation on how long an implied warranty lasts. If such laws apply, the limitations or exclusions expressed herein may not apply to PURCHASER.
- II. Unless otherwise explicitly agreed in writing, it is understood that these are the only written warranties given by HPS™. Any statements made by any persons, including representatives of HPS™, which are inconsistent or in conflict with the terms of the warranty shall not be binding on HPS™ unless reduced to writing and approved by an authorized officer of HPS™.
- III. This warranty gives PURCHASER specific legal rights, and PURCHASER may also have other rights which vary from state to state.
- IV. For HPS™ products sold outside of the U.S., contact your MKS representative for warranty information and service.

Warranty Performance

To obtain warranty satisfaction, contact the following: MKS Instruments, Inc., HPS™ Products, Inc., 5330 Sterling Drive, Boulder, CO 80301, USA, at phone number (303) 449-9861.

Notes



