



HPS® Products

Series 919

Hot Cathode Ionization

High Vacuum

Sensor System

OPERATION AND MAINTENANCE MANUAL



HPS® Products
Series 919
Hot Cathode Ionization
High Vacuum
Sensor System

May 1997 Part # 109190098 Rev. B1

Hot Cathode Ionization High Vacuum Sensor System

Part # 919-A-XXX-XX

____ - ____

Serial # _____

Please fill in these numbers and have them readily available when calling for service or additional information.

(The part number can be found on your packing slip, and the serial number is located on the rear panel of the Controller.)

For more information or literature, contact:

MKS Instruments, HPS® Division Inc.
5330 Sterling Drive
Boulder, CO 80301 USA

Phone: 303-449-9861
800-345-1967

FAX: 303-442-6880

© 1997 by MKS Instruments, HPS® Division Inc. All rights reserved.

Inconel is a registered trademark of Inco Alloys International, Inc.
SensaVac is a trademark of MKS Instruments, Inc.

Hot Cathode Ionization High Vacuum Sensor System

Table of Contents

Table of Contents	
Package Contents	1
Symbols Used in this Manual	2
Symboles utilisés dans ce manuel	3
In dieser Betriebsanleitung vorkommende Symbole	4
Símbolos Usados en el Manual	5
Symbols Found on the Unit	6
Symboles apparaissant sur l'appareil	7
Am Gerät angebrachte Symbole	8
Símbolos que Aparecen en la Unidad	9
Safety Procedures and Precautions	10
Mesures de Sécurité et Mises en Garde	12
Sicherheitsvorschriften und Vorsichtsmaßnahmen	14
Procedimientos y Precauciones de Seguridad	16
Specifications	18
Controller	18
Sensor	20
Feature and Control Locations	21
Typical Applications for the Series 919 Hot Cathode System..	23
About the HPS® Products Series 919	
Hot Cathode Ionization System	24
Installing and Setting Up the Series 919 Hot Cathode System	25
Hot Cathode Sensor Installation	25
Location	25
Orientation	25
Contamination	25
Vacuum Connection	25
Hot Cathode Controller Installation	25
Operating the Series 919 Hot Cathode System	30
Reading Pressure	30
Using the Analog Output	30
Adjusting the Set Points	31
Adjusting the Filament Protection Limit	32
Restarting the Filament	32
Local Method	32
Remote Method	32
Setting the Sensor Sensitivity	33
Sensor Sensitivity for Different Pressure Units	33

Degassing the Sensor	33
Preparing for Sensor Bakeout	34
Using the Series 919 Hot Cathode System with Other Gases .	35
Adjusting System Sensitivity for Another Gas	35
Maintaining the Series 919 Hot Cathode System	37
Cleaning the Controller Front Panel	37
Servicing the Controller	37
Replacing a Power Fuse	37
Testing the Sensor	38
Accessories	39
Product Warranty	40
Appendix A: How the Series 919 Hot Cathode System Works	41
Theory of a Hot Cathode Ionization Sensor	41
HPS® Sensors	41
Notes	42

Package Contents

Before unpacking your Series 919 Hot Cathode Ionization High Vacuum Sensor System, check all surfaces of the packing material for shipping damage.

Please be sure that your Series 919 Hot Cathode System package contains these items:

- ◆ 1 Series 919 Hot Cathode Controller
- ◆ 1 power cord
- ◆ 1 female, 15-pin subminiature D ("D" type) *Accessory* connector kit
- ◆ 4 Controller surface pads, rubber
- ◆ 1 *HPS® Series 919 Hot Cathode Ionization High Vacuum Sensor System* User's Manual.

The Series 919 System's Sensor and its connecting cable are sold separately. Please refer to page 39 for necessary ordering information if you have not already ordered them.



If any items are missing from the package, call HPS® Customer Service at 1-303-449-9861 or 1-800-345-1967.

Inspect the Series 919 Hot Cathode System for visible evidence of damage. If it has been damaged in shipping, notify the carrier immediately. Keep all shipping materials and packaging for claim verification. Do **not** return the product to HPS®.

Symbols Used in this Manual

Definitions of CAUTION and NOTE messages used throughout the manual.



CAUTION: Risk of electrical shock. ISO 3864, No. B.3.6



CAUTION: *Refer to accompanying documents.*
ISO 3864, No. B.3.1

This sign denotes a hazard. It calls attention to a procedure, practice, condition, or the like, which, if not correctly performed or adhered to, could result in injury to personnel.



This sign denotes a hazard. It calls attention to an operating procedure, practice, or the like, which, if not correctly performed or adhered to, could result in damage to or destruction of all or part of the product.



This sign denotes important information. It calls attention to a procedure, practice, condition, or the like, which is essential to highlight.

Symboles utilisés dans ce manuel

Définition des indications ATTENTION et REMARQUE utilisées dans ce manuel.



ATTENTION: Risque de secousse électrique.
ISO 3864, No. B.3.6



ATTENTION: *Se reporter à la documentation.*
ISO 3864, No. B.3.1

L'indication signale un danger potentiel. Elle est destinée à attirer l'attention sur une procédure, une utilisation, une situation ou toute autre chose présentant un risque de blessure en cas d'exécution incorrecte ou de non-respect des consignes.



L'indication signale un danger potentiel. Elle est destinée à attirer l'attention sur une procédure, une utilisation, une situation ou toute autre chose présentant un risque d'endommagement ou de dégât d'une partie ou de la totalité de l'appareil en cas d'exécution incorrecte ou de non-respect des consignes.



L'indication REMARQUE signale des informations importantes. Elle est destinée à attirer l'attention sur une procédure, une utilisation, une situation ou toute autre chose présentant un intérêt particulier.

In dieser Betriebsanleitung vorkommende Symbole

Definition der mit VORSICHT! und HINWEIS überschriebenen Abschnitte in dieser Betriebsanleitung.



VORSICHT!

Stromschlaggefahr! ISO 3864, Nr. B.3.6



VORSICHT!

***Bitte Begleitdokumente lesen!
ISO 3864, Nr. B.3.1***

Das Symbol VORSICHT! weist auf eine Gefahrenquelle hin. Es macht auf einen Arbeitsablauf, eine Arbeitsweise, einen Zustand oder eine sonstige Gegebenheit aufmerksam, deren unsachgemäße Ausführung bzw. Ungenügende Berücksichtigung zu Körperverletzung führen kann.



Das Symbol VORSICHT! weist auf eine Gefahrenquelle hin. Es macht auf einen Bedienungsablauf, eine Arbeitsweise oder eine sonstige Gegebenheit aufmerksam, deren unsachgemäße Ausführung bzw. Ungenügende Berücksichtigung zu einer Beschädigung oder Zerstörung des Produkts oder von Teilen des Produkts führen kann.



Das Symbol HINWEIS weist auf eine wichtige Mitteilung hin, die auf einen Arbeitsablauf, eine Arbeitsweise, einen Zustand oder eine sonstige Gegebenheit von besonderer Wichtigkeit aufmerksam macht.

Símbolos Usados en el Manual

Definiciones de los mensajes de PRECAUCIÓN y OBSERVACIÓN usados en el manual.



PRECAUCIÓN: Riesgo de descarga eléctrica. ISO 3864, Nr. B.3.6



PRECAUCIÓN: *Consultar los documentos adjuntos. ISO 3864, Nr. B.3.1*

Este símbolo indica un riesgo. Pone de relieve un procedimiento, práctica, condición, etc., que, de no realizarse u observarse correctamente, podría causar lesiones a los empleados.















Este símbolo indica un riesgo. Pone de relieve un procedimiento, práctica, etc., de tipo operativo que, de no realizarse u observarse correctamente, podría causar desperfectos al instrumento, o llegar incluso a causar su destrucción total o parcial.

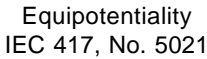

Este símbolo indica información de importancia. Pone de relieve un procedimiento, práctica, condición, etc., cuyo conocimiento resulta esencial.













Symbols Found on the Unit

The following table describes symbols that may be found on the unit.

Definition of Symbols Found on the Unit			
			
<p>On (Power) IEC 417, No. 5007</p>	<p>Off (Power) IEC 417, No. 5008</p>	<p>Earth (Ground) IEC 417, No. 5017</p>	<p>Protective Earth (Ground) IEC 417, No. 5019</p>
			
<p>Frame or Chassis IEC 417, No. 5020</p>	<p>Equipotentiality IEC 417, No. 5021</p>	<p>Direct Current IEC 417, No. 5031</p>	<p>Alternating Current IEC 417, No. 5032</p>
			
<p>Direct and Alternating Current, Both IEC 417, No. 5033-a</p>	<p>Class II Equipment IEC 417, No. 5172-a</p>	<p>Three-phase Alternating Current IEC617-2, No. 020206</p>	
			
<p>Caution, refer to accompanying documents ISO 3864, No. B.3.1</p>	<p>Caution, risk of electric shock ISO 3864, No. B.3.6</p>	<p>Caution, hot surface IEC 417, No. 5041</p>	















Symboles apparaissant sur l'appareil

Le tableau suivant décrit les symboles apparaissant sur l'appareil.

Définition des symboles apparaissant sur l'appareil			
 Marche (mise sous tension) IEC 417, No. 5007	 Arrêt (hors tension) IEC 417, No. 5008	 Terre IEC 417, No. 5017	 Terre de protection IEC 417, No. 5019
 Masse, Châssis IEC 417, No. 5020	Equipotentialité IEC 417, No. 5021	 Courant continue IEC 417, No. 5031	 Courant alternatif IEC 417, No. 5032
 Courant continu et alternatif IEC 417, No. 5033-a	 Matériel de la Classe II IEC 417, No. 5172-a	 Courant alternatif triphasé IEC617-2, No. 020206	
 Attention: se reporter à la documentation ISO 3864, No. B.3.1	 Attention: risque de secousse électrique ISO 3864, No. B.3.6	 Attention: surface brûlante IEC 417, No. 5041	













Am Gerät angebrachte Symbole

Der untenstehenden Tabelle sind die Bedeutungen der Symbole zu entnehmen, die an dem Gerät angebracht sind.

Definitionen der am Gerät angebrachten Symbole			
			
Ein (Netz) IEC 417, Nr. 5007	Aus (Netz) IEC 417, Nr. 5008	Erde IEC 417, Nr. 5017	Schutzleiter IEC 417, Nr. 5019
			
Rahmen oder Chassis IEC 417, Nr. 5020	Äquipotentialanschluß IEC 417, Nr. 5021	Gleichstrom IEC 417, Nr. 5031	Wechselstrom IEC 417, Nr. 5032
			
Wechselstrom und Gleichstrom IEC 417, Nr. 5033-a	Geräteklasse II IEC 417, Nr. 5172-a	Drehstrom IEC 617-2 Nr. 020206	
			
Vorsicht! Bitte Begleitdokumente lesen! ISO 3864, Nr. B.3.1	Vorsicht! Stromschlaggefahr! ISO 3864, Nr. B.3.6	Vorsicht! Heiße Fläche! IEC 417, Nr. 5041	

Símbolos que Aparecen en la Unidad

En la tabla que figura a continuación se indican los símbolos que aparecen en la unidad.

Definición de los símbolos que aparecen en la unidad			
 Encendido (alimentación eléctrica) IEC 417, N.º 5007	 Apagado (alimentación eléctrica) IEC 417, N.º 5008	 Puesta a tierra IEC 417, N.º 5017	 Protección a tierra IEC 417, N.º 5019
 Caja o chasis IEC 417, N.º 5020	Equipotencialidad IEC 417, N.º 5021	 Corriente continua IEC 417, N.º 5031	 Corriente alterna IEC 417, N.º 5032
 Corriente continua y alterna IEC 417, N.º 5033-a	 Equipo de clase II IEC 417, N.º 5172-a	 Corriente alterna trifásica IEC 617-2 N.º 020206	
 Precaución. Consultar los documentos adjuntos ISO 3864, N.º B.3.1	 Precaución. Riesgo de descarga eléctrica ISO 3864, N.º B.3.6	 Precaución. Superficie caliente IEC 417, N.º 5041	

Safety Procedures and Precautions

The following general safety precautions must be observed during all phases of operation of this instrument. Failure to comply with these precautions or with specific warnings elsewhere in this manual violates safety standards of intended use of the instrument and may impair the protection provided by the equipment. MKS Instruments, HPS® Products, Inc. assumes no liability for the customer's failure to comply with these requirements.



The Series 919 Controller contains lethal voltages when on.

High voltage is present in the cable and the Hot Cathode Sensor when the Controller is turned on.



Properly ground the Controller.

This product is grounded through the grounding conductor of the power cord. To avoid electrical shock, plug the power cord into a properly wired receptacle before connecting it to the product input or output terminals. A protective ground connection by way of the grounding conductor in the power cord is essential for safe operation.

Upon loss of the protective-ground connection, all accessible conductive parts (including knobs and controls that may appear to be insulating) can render an electrical shock.



Do not substitute parts or modify instrument.

Do not install substitute parts or perform any unauthorized modification to the instrument. Return the instrument to an MKS Calibration and Service Center for service and repair to ensure that all safety features are maintained.



Use the proper fuse.

Use only a fuse of the correct type, voltage rating, and current rating, as specified for your product.



Use proper electrical fittings.

Dangerous voltages are contained within this instrument. All electrical fittings and cables must be of the type specified, and in good condition. All electrical fittings must be properly connected and grounded.



Use the proper power source.

This product is intended to operate from a power source that does not apply more voltage between the supply conductors, or between either of the supply conductors and ground, than that specified in the manual.



Do not operate in explosive environments.

To avoid explosion, do not operate this product in an explosive environment unless it has been specifically certified for such operation.



Service by qualified personnel only.

Operating personnel must not remove instrument covers. Component replacement and internal adjustments must be made by qualified service personnel only.



Use the proper power cord.

Use only a power cord that is in good condition and which meets the input power requirements specified in the manual.

Use only a detachable cord set with conductors that have a cross-sectional area equal to or greater than 0.75 mm². The power cable should be approved by a qualified agency such as VDE, Semko, or SEV.

Mesures de Sécurité et Mises en Garde

Prendre toutes les précautions générales suivantes pendant toutes les phases d'utilisation de cet appareil. Le non-respect de ces précautions ou des avertissements contenus dans ce manuel entraîne une violation des normes de sécurité relatives à l'utilisation de l'appareil et le risque de réduire le niveau de protection fourni par l'appareil. MKS Instruments, HPS® Division, Inc. ne prend aucune responsabilité pour les conséquences de tout non-respect des consignes de la part de ses clients.



Danger de haute tension.

Une haute tension est présente dans le câble et dans le capteur lorsque le contrôleur est sous tension.



Mise à la terre de l'appareil.

Cet appareil est mis à la terre à l'aide du fil de terre du cordon d'alimentation. Pour éviter tout risque de secousse électrique, brancher le cordon d'alimentation sur une prise de courant correctement câblée avant de le brancher sur les bornes d'entrée ou de sortie de l'appareil. Une mise à la terre de protection à l'aide du fil de terre du cordon d'alimentation est indispensable pour une utilisation sans danger de l'appareil.

En cas de défaut de terre, toutes les pièces conductrices accessibles (y compris les boutons de commande ou de réglage qui semblent être isolés) peuvent être source d'une secousse électrique.



Ne pas substituer des pièces ou modifier l'appareil.

Ne pas utiliser de pièces détachées autres que celles vendues par MKS Instruments, Inc. ou modifier l'appareil sans l'autorisation préalable de MKS Instruments, Inc. Renvoyer l'appareil à un centre d'étalonnage et de dépannage MKS pour tout dépannage ou réparation afin de s'assurer que tous les dispositifs de sécurité sont maintenus.



Utilisation d'un fusible approprié.

Utiliser uniquement un fusible conforme au type, à la tension nominale et au courant nominal spécifiés pour l'appareil.



Mise à la terre et utilisation correcte d'accessoires électriques.

Des tensions dangereuses existent à l'intérieur de l'appareil. Tous les accessoires et les câbles électriques doivent être conformes au type spécifié et être en bon état. Tous les accessoires électriques doivent être correctement connectés et mis à la terre.



Utilisation d'une alimentation appropriée.

Cet appareil est conçu pour fonctionner en s'alimentant sur une source de courant électrique n'appliquant pas une tension entre les conducteurs d'alimentation, ou entre les conducteurs d'alimentation et le conducteur de terre, supérieure à celle spécifiée dans le manuel.



Ne pas utiliser dans une atmosphère explosive.

Pour éviter tout risque d'explosion, ne pas utiliser l'appareil dans une atmosphère explosive à moins qu'il n'ait été approuvé pour une telle utilisation.



Dépannage effectué uniquement par un personnel qualifié.

L'opérateur de l'appareil ne doit pas enlever le capot de l'appareil. Le remplacement des composants et les réglages internes doivent être effectués uniquement par un personnel d'entretien qualifié.



Utilisation d'un cordon d'alimentation approprié.

Utiliser uniquement un cordon d'alimentation en bon état et conforme aux exigences de puissance d'entrée spécifiées dans le manuel.

Utiliser uniquement un cordon d'alimentation amovible avec des conducteurs dont la section est égale ou supérieure à 0,75 mm². Le cordon d'alimentation doit être approuvé par un organisme compétent tel que VDE, Semko ou SEV.

Sicherheitsvorschriften und Vorsichtsmaßnahmen

Die untenstehenden allgemeinen Sicherheitsvorschriften sind bei allen Betriebsphasen dieses Instruments zu befolgen. Jede Mißachtung dieser Sicherheitsvorschriften oder sonstiger spezifischer Warnhinweise in dieser Betriebsanleitung stellt eine Zuwiderhandlung der für dieses Instrument geltenden Sicherheitsstandards dar und kann die an diesem Instrument vorgesehenen Schutzvorrichtungen unwirksam machen. MKS Instruments, HPS® Products, Inc. haftet nicht für eine Mißachtung dieser Sicherheitsvorschriften seitens des Kunden.



Hochspannungsgefahr!

Bei eingeschaltetem Steuerteil liegt im Kabel und im Sensor Hochspannung an.



Produkerden!

Dieses Produkt ist mit einer Erdleitung und einem Schutzkontakt am Netzstecker versehen. Um der Gefahr eines elektrischen Schlages vorzubeugen, ist das Netzkabel an einer vorschriftsmäßig geerdeten Schutzkontaktsteckdose anzuschließen, bevor es an den Eingangs- bzw. Ausgangsklemmen des Produkts angeschlossen wird. Das Instrument kann nur sicher betrieben werden, wenn es über den Erdleiter des Netzkabels und einen Schutzkontakt geerdet wird.

Geht die Verbindung zum Schutzleiter verloren, besteht an sämtlichen zugänglichen Teilen aus stromleitendem Material die Gefahr eines elektrischen Schlages. Dies gilt auch für Knöpfe und andere Bedienelemente, die dem Anschein nach isoliert sind.



Keine Teile austauschen und keine Veränderungen vornehmen!

Bauen Sie in das Instrument keine Ersatzteile ein, und nehmen Sie keine eigenmächtigen Änderungen am Gerät vor! Schicken Sie das Instrument zu Wartungs- und Reparaturzwecken an einen MKS-Kalibrierungs- und Kundendienst ein! Dadurch wird sichergestellt, daß alle Sicherheitseinrichtungen voll funktionsfähig bleiben.



Richtige Sicherung benutzen!

Es ist eine Sicherung zu verwenden, deren Typ, Nennspannung und Nennstromstärke den Angaben für dieses Produkt entsprechen.



Erdung und Verwendung geeigneter elektrischer Armaturen!

In diesem Instrument liegen gefährliche Spannungen an. Alle verwendeten elektrischen Armaturen und Kabel müssen dem angegebenen Typ entsprechen und sich in einwand-freiem Zustand befinden. Alle elektrischen Armaturen sind vorschriftsmäßig anzubringen und zu erden.



Richtige Stromquelle verwenden!

Dieses Produkt ist für eine Stromquelle vorgesehen, bei der die zwischen den Leitern bzw. zwischen jedem der Leiter und dem Masseleiter anliegende Spannung den in dieser Betriebsanleitung angegebenen Wert nicht überschreitet.



Gerät nicht in explosiver Atmosphäre benutzen!

Um der Gefahr einer Explosion vorzubeugen, darf dieses Gerät nicht in der Nähe explosiver Stoffe eingesetzt werden, sofern es nicht ausdrücklich für diesen Zweck zertifiziert worden ist.



Wartung nur durch qualifizierte Fachleute!

Das Gehäuse des Instruments darf vom Bedienpersonal nicht geöffnet werden. Das Auswechseln von Bauteilen und das Vornehmen von internen Einstellungen ist nur von qualifizierten Fachleuten durchzuführen.



Richtiges Netzkabel verwenden!

Das verwendete Netzkabel muß sich in einwandfreiem Zustand befinden und den in der Betriebsanleitung enthaltenen Anschlußwerten entsprechen.

Das Netzkabel muß abnehmbar sein. Der Querschnitt der einzelnen Leiter darf nicht weniger als 0,75 mm² betragen. Das Netzkabel sollte einen Prüfvermerk einer zuständigen Prüfstelle tragen, z.B. VDE, Semko oder SEV.

Procedimientos y Precauciones de Seguridad

Las precauciones generales de seguridad que figuran a continuación deben observarse durante todas las fases de funcionamiento del presente instrumento. La no observancia de dichas precauciones, o de las advertencias específicas a las que se hace referencia en el manual, contraviene las normas de seguridad referentes al uso previsto del instrumento y podría impedir la protección que proporciona el instrumento. MKS Instruments, HPS® Division, Inc., no asume responsabilidad alguna en caso de que el cliente haga caso omiso de estos requerimientos.



Peligro por alto voltaje.

Cuando el controlador está encendido, se registra alto voltaje en el cable y en el sensor.



Puesta a tierra del instrumento.

Este instrumento está puesto a tierra por medio del conductor de tierra del cable eléctrico. Para evitar descargas eléctricas, enchufar el cable eléctrico en una toma debidamente instalada, antes de conectarlo a las terminales de entrada o salida del instrumento. Para garantizar el uso sin riesgos del instrumento resulta esencial que se encuentre puesto a tierra por medio del conductor de tierra del cable eléctrico.

Si se pierde la conexión protectora de puesta a tierra, todas las piezas conductoras a las que se tiene acceso (incluidos los botones y mandos que pudieran parecer estar aislados) podrían producir descargas eléctricas.



No utilizar piezas no originales ni modificar el instrumento.

No se debe instalar piezas que no sean originales ni modificar el instrumento sin autorización. Para garantizar que las prestaciones de seguridad se observen en todo momento, enviar el instrumento al Centro de servicio y calibración de MKS cuando sea necesaria su reparación y servicio de mantenimiento.



Usar el fusible adecuado.

Usar únicamente un fusible del tipo, clase de voltaje y de corriente adecuados, según lo que se especifica para el instrumento.



Usar los accesorios eléctricos adecuados.

Este instrumento funciona con voltajes peligrosos. Todos los accesorios y cables eléctricos deben ser del tipo especificado y mantenerse en buenas condiciones. Todos los accesorios eléctricos deben estar conectados y puestos a tierra del modo adecuado.



Usar la fuente de alimentación eléctrica adecuada.

Este instrumento debe funcionar a partir de una fuente de alimentación eléctrica que no aplique más voltaje entre los conductores de suministro, o entre uno de los conductores de suministro y la puesta a tierra, que el que se especifica en el manual.



Evitar su uso en entornos explosivos.

Para evitar el riesgo de explosión, no usar este instrumento o en un entorno explosivo, a no ser que haya sido certificado para tal uso.



Reparaciones efectuadas únicamente por técnicos especializados.

Los operarios no deben retirar las cubiertas del instrumento. El cambio de piezas y los reajustes internos deben efectuarlos únicamente técnicos especializados.



Usar el cable eléctrico adecuado.

Usar únicamente un cable eléctrico que se encuentre en buenas condiciones y que cumpla los requisitos de alimentación de entrada indicados en el manual.

Usar únicamente un cable desmontable instalado con conductores que tengan un área de sección transversal equivalente o superior a 0,75mm². El cable eléctrico debe estar aprobado por una entidad autorizada como, por ejemplo, VDE, Semko o SEV.

Specifications

Controller

Measuring Range	1.0 x 10 ⁻¹⁰ to 1.0 x 10 ⁻² Torr 1.3 x 10 ⁻¹⁰ to 1.3 x 10 ⁻² mbar 1.3 x 10 ⁻⁸ to 1.3 x 10 ⁰ Pa
Set Point Range	1.0 x 10 ⁻¹⁰ to 1.0 x 10 ⁻² Torr 1.3 x 10 ⁻¹⁰ to 1.3 x 10 ⁻² mbar 1.3 x 10 ⁻⁸ to 1.3 x 10 ⁰ Pa
Reproducibility	Approximately ±5%
Operating Temperature Range	5° to 40°C (41° to 104°F)
Storage Temperature Range	-10° to 55°C (14° to 131°F)
Relative Humidity	80% max for T < 31°C, decreasing linearly to 50% max at 40°C
Altitude	2000 m (6562 ft) max
Insulation Coordination	Installation (Overvoltage) Category II, Pollution Degree 2
Mains Voltage	Fluctuations not to exceed ±10%
Number of Channels	1
Process Control	Two nonvolatile, independently set, pressure dependent set point relays
Relay Contact Rating	5 A @ 120 VAC or 24 VDC resistive load, SPDT
Relay Response	50 to 1000 msec (pressure range dependent)
Front Panel Controls	Power on-off rocker switch; display push-buttons and adjustment potentiometers for set points, protection, and sensitivity; degas and filament on-off-remote toggle switches
Range for Sensor Sensitivity	4 to 50 Torr ⁻¹

Power Requirement	100, 120, 220, or 240 VAC 50 or 60 Hz
Power Consumption	120 W max
Degas Power	30 W max (I ² R)
Filament Power Supply	8 VAC @ 4.5 A max
Output Voltage	Proportional to log ₁₀ of pressure 1 V per decade (1 to 9 V)
Emission Current	1 mA at P < 1.0 x 10 ⁻⁴ Torr 100 uA at P > 8.0 x 10 ⁻⁵ Torr, regulated to 3%
Fuse Rating, Size	T 1.25 A for 100 VAC T 1.00 A for 120 VAC T 0.63 A for 220 VAC T 0.50 A for 240 VAC all are Ø 5 mm x 20 mm
Display	Green LED with 2 significant digits (1 leading) and 1½ digit signed exponent; 7-segment digits, 14 mm in height; units shown in either Torr, mbar, or Pascal
Indicators	Green LEDs for set points, filament, and degas status
Update Rate	7.5 times/sec
Electronic Casing	Aluminum, anodized
Dimensions (W x D x H)	9½" x 9½" x 3½" (241 mm x 241 mm x 89 mm)
Size	½ rack
Weight	7.5 lb (3.4 kg)
Product Safety	CE Mark 89/336/EEC EMC Directive 73/23/EEC LV Directive

Sensor

Type	Bayard-Alpert Low Power Nude
Sensitivity	9 Torr ⁻¹ (±20%)
Degas Power	40 W max
Operating Voltage	
Grid	180 VDC
Filament bias	30 VDC
Filament	4.7 VAC @ 1.8 A
Calibration Gas	Air/nitrogen
Installation Orientation	Any
Materials Exposed to Vacuum	304 SS, Inconel® X-750, glass, tungsten, platinum, nickel, either yttria-coated iridium or tungsten
Operating Temperature Range	0° to 50°C (32° to 122°F)
Bakeout Temperature	300°C max, with CF 150°C max, with KF and Viton®
Typical Weight (with CF Flange)	0.9 lb (0.4 kg)
Vacuum Connection	2¾" CF (non-rotatable) KF 40

Design and/or specifications subject to change without notice.

Feature and Control Locations

Controller

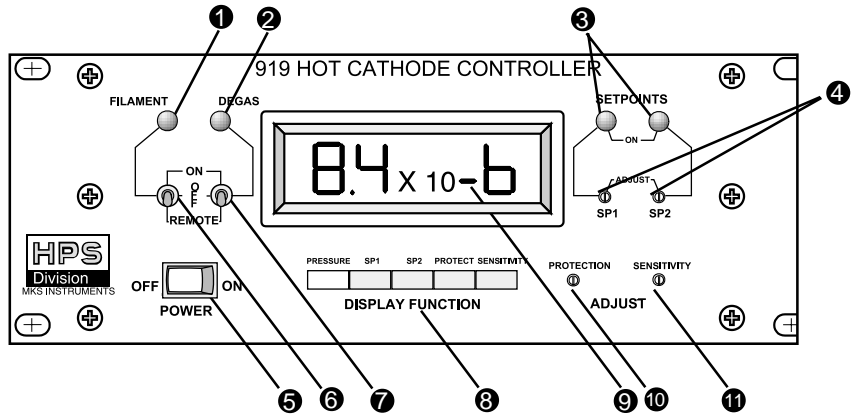

Front Panel

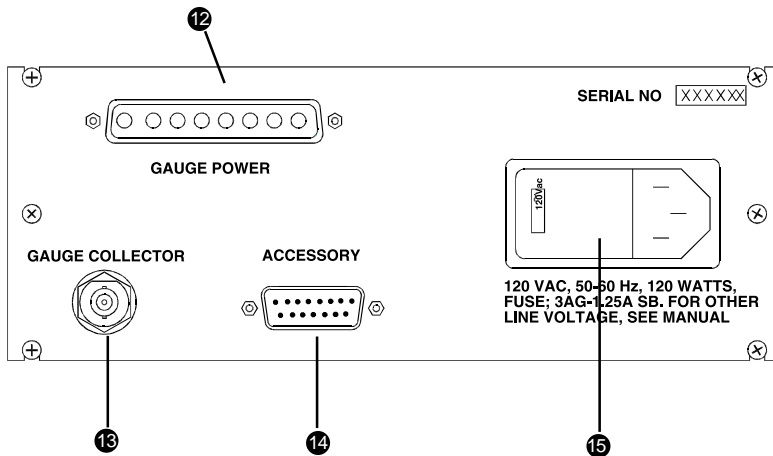

Rear Panel

- | | |
|--|---|
| ① LED Filament Indicator | ⑨ LED Digital Display |
| ② LED Degas Indicator | ⑩ Protection Adjustment Potentiometer |
| ③ LED Set Point Indicators | ⑪ Sensitivity Adjustment Potentiometer |
| ④ Set Point Adjustment Potentiometers | ⑫ Female, 8-pin, High Power "D" type |
| ⑤ Power On-Off Rocker Switch | ⑬ Gauge Power Connector |
| ⑥ Filament On-Off-Remote Toggle Switch | ⑭ Female, BNC Gauge Collector |
| ⑦ Degas On-Off-Remote Toggle Switch | ⑮ Connector Male, 15-pin Accessory Port |
| ⑧ Display Push-buttons (Pressure, Set Points, Protection, and Sensitivity) | Power Cord Inlet w/ Fuse Holder and Line Voltage Selector |

Sensor

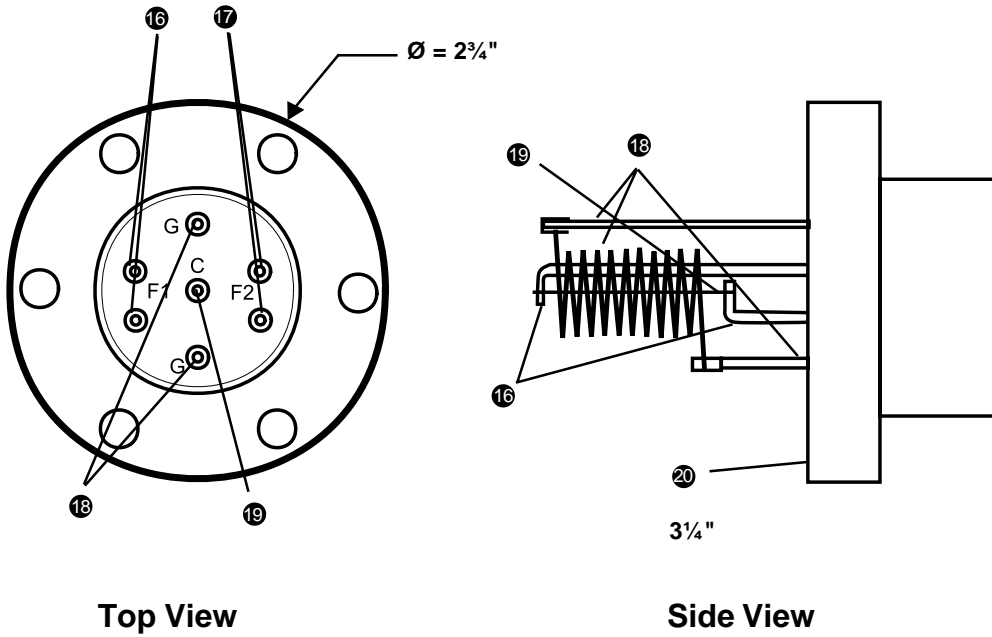

- 16 Filament 1
- 17 Filament 2
- 18 Grid and Supports
- 19 Ion Collector
- 20 Sensor Vacuum Port and Flange

Typical Applications for the Series 919 Hot Cathode System



Measurement of high vacuum chamber pressures



Control of high vacuum systems and process sequencing using a relay set point



Sensing abnormal pressure and taking appropriate security measures using a relay set point



Controlling system pressure using an automatic pressure control system



Starting or stopping system processes with the relay set point



Measuring pressures of backfilled gases



Leak testing your vacuum system

About the HPS® Products Series 919 Hot Cathode Ionization System

The Series 919 Hot Cathode Ionization System, with its wide measurement range of 10^{-2} down to 10^{-10} Torr, is designed for versatility, simplicity, reliability, and value. A large, green LED display is easy to read in almost any lighting or angle. Pressure, sensitivity, protection, and set point values are shown in exponential notation. Other LEDs indicate filament, degas, and set point activation status. All controls, including power, are conveniently located on the front panel, and cable connections are hidden to the rear of the Controller.

Standard features of the Series 919 Controller include two nonvolatile set points for reliable system control, remote enable for filament and degas, and burnout protection for the filament. The protection feature guards the Sensor's filament against damage in case of overpressure or a short circuit. The pressure at which the filament is turned off is adjustable.

The Controller's resistance (I^2R) degas conveniently and effectively removes adsorbed gas from the Sensor. Unlike most other hot cathode ionization controllers, the Series 919 Controller displays pressure during degas. Remote filament and degas controls allow easy automation.

Measurements are more precise with superior electromagnetic and RF noise shielding and very stable electronics. The specially designed Controller electrometer provides high amplification, a stable zero point, and fast time constants for rapidly changing measurement situations. This is especially useful with pressure controllers.



Installing and Setting Up the Series 919 Hot Cathode System

Hot Cathode Sensor Installation

Location

Locate the Sensor where it can measure chamber or manifold pressure. Installing the Sensor away from pumps and gas sources gives the most representative pressure values.

Orientation

The Series 919 Hot Cathode Sensor can be installed and operated in any position without compromising accuracy.

Contamination

Locate and orient the Sensor where contamination is least likely. For example, if the Sensor is mounted directly above a source of evaporation, the vapor could contaminate the filament wire and cause the calibration to shift.

Install the Sensor with the vacuum port facing down whenever possible to keep particulates or liquids from entering the Sensor. Using a screen or porous filter at the port is helpful (see **Accessories**, p. 39).

Shield a Sensor located near an electron or ion source (e.g., near an electron beam source or in a sputtering system) to prevent inaccurate pressure measurements.

Vacuum Connection

The Series 919 Hot Cathode Sensor is available with either a 2¾" CF (non-rotatable) or a KF 40 flange. A Sensor with a KF flange and elastomer O-ring is suitable only for pressure measurement down to 10^{-7} Torr. Viton® or another fluor elastomer should be used.

Do not damage the electrodes or feed through when inserting the Sensor into your system. Do not short the elements to one another, the chamber, or the components inside the chamber.

Hot Cathode Controller Installation

Selecting a Line Voltage

A switch to change line voltage is located on the Controller's back panel fuse box/AC power connector.

The Controller operates with line frequencies of 50 or 60 Hz without any adjustment necessary. It is configured at the factory to operate at either 100, 120, 220, or 240 VAC.

To change a line voltage,

- 1 Unplug the power cord from the Controller.
- 2 Insert a screwdriver blade under the tab to the left of the voltage display on the power connector. Gently twist the screwdriver to open the cover and expose the voltage selector drum and the fuse.
- 3 Pull out the selector drum, as shown in the exploded view at right, and rotate it until the correct nominal line voltage faces you. The available choices are shown below. Be sure to use the correct fuse with the chosen line voltage.
- 4 Replace the drum in its bracket, and close the cover.

Voltage, Range Fuse (V)	Voltage, (V)	Nominal (A)
90 to 110	100	T 1.25
110 to 130	120	T 1.00
210 to 230	220	T 0.63
230 to 250	240	T 0.50

Controller Mounting

The Series 919 Hot Cathode Controller is designed for either rack mounting or for stand-alone use. Regardless of the method you choose, assure adequate ventilation to the Controller with at least 1 inch left open above the top perforated panel.

For bench top use, adhesive backed rubber pads are provided. Remove the adhesive backing from each pad and apply one to each corner of the aluminum bottom surface.

Optional mounting hardware is available for mounting the half-rack casing in a 19-inch rack frame and trim panel or in the frame with a splicing plate (see **Accessories**, p. 39).

To mount two Controllers or one Controller with one face plate in a rack, as shown on the left at the top of the next page,

- 1 Hold or stabilize the Controller in the rack while securing the front panel of the Controller to one side of the rack with the screws provided.
- 2 Attach the small splicing plate to the back side of the other end of the front panel.

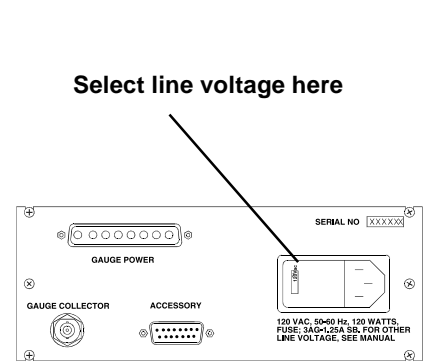

Controller rear panel

Voltage selector drum

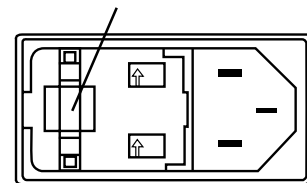

AC power connector with fuse box

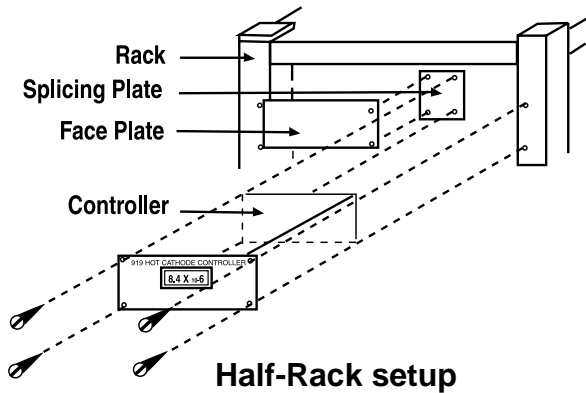

Half-Rack setup

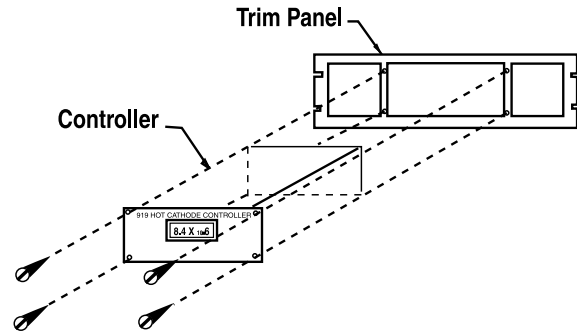

Rack with trim panel setup

- 3 Add a face plate or secure another controller to the other half of the rack. Secure to the rack and to the other side of the splicing plate.

To mount the Controller into a trim panel on the rack, as shown in the right figure above,

- 1 Slip the Controller into the trim panel through the cutout.
- 2 Fasten the corners of the Controller's front panel to the trim panel with the four screws provided.

Connecting the Sensor to the Controller

A Low Power Nude Sensor cable, with a molded BNC connector and a molded, high power "D" type connector, is required for operation but is purchased separately from the Series 919 Hot Cathode System (see **Accessories**, p. 39).



Turn off the Controller before plugging or unplugging a cable to the Sensor.

Connecting or disconnecting cables while the Controller is on may damage the Sensor.

The configuration of the cable pins is symmetrical, as shown to the left. When you would like to switch from filament F1 to F2, or vice versa, rotate the sensor cable 180° to use the opposite set of filaments.

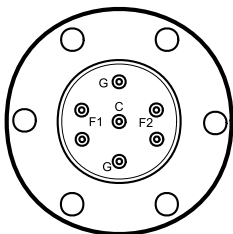

When exerting excessive stress on the cable, use separate strain relief to prevent damage to the Sensor or Controller. Cables are available from HPS® in standard lengths of 10, 25, and 50 ft and in custom lengths up to 50 ft (see **Accessories**, p. 39).

Sensor cables can be as long as 50 ft (15 m) without losing accuracy or changing Sensor calibration. However, cable resistance does decrease available degas power as the length of cable increases.

AC Power Cord

The Series 919 System includes a standard 120 VAC, 50/60 Hz power cord with a female IEC-320 connector.

If the available power source or connection is different, use only a detachable cord set with conductors that have a cross-sectional area equal to or greater than 0.75 mm². The power cable should be approved by a qualified agency such as VDE, Semko, or SEV.

Accessory Connector

Relay set point contacts and analog output voltage can be accessed from the *Accessory* port on the rear panel of the Controller. A mating connector kit is included with the Series 919 Hot Cathode System. The chart and figure below identify the pin functions of the *Accessory* port.



Do not inadvertently short circuit the set point relay terminals to the analog output voltage or to other Controller functions.

Connect the following pins (9, 10, or 13) to a TTL low voltage or to ground to:

Pin 9 – Disable all Controller functions, Sensor voltage, and set point relays.

Pin 10 – Turn on the filament and grid voltage. The front panel *Filament* switch must be set to remote.

Use pins 9 or 10 to connect the Controller to a medium pressure sensor, such as a Pirani, to interlock the Hot Cathode Sensor to it and turn the Hot Cathode Sensor off and on when appropriate.

Pin	Description
1	set point relay 1 - normally closed contact
2	set point relay 1 - common
3	set point relay 1 - normally open contact
4	set point relay 2 - normally closed contact
5	set point relay 2 - common
6	set point relay 2 - normally open contact
7	not used
8	not used
9	Controller - disable
10	remote filament - enable
11	analog output voltage (+)
12	ground
13	remote degas - enable
14	Low Emission Current monitor
15	not used

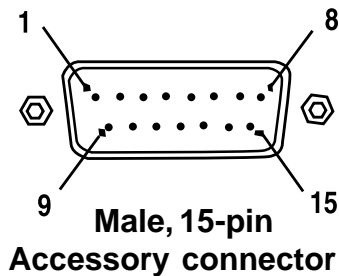

Pin 13 – Turn on the degas. The front panel *Degas* switch must be set to remote and either the front panel *Filament* switch is set to on or pin 10, remote filament-enable, is connected to a TTL low voltage or ground.

If the filament turns off, degas will turn off automatically. To restart degas, the filament must be restarted either with the front panel *Filament* switch or through the *Accessory* connector.

To turn off degas, allow this remote degas-enable pin to rise to a TTL high level or to be released from the TTL low voltage or ground so that the Controller's circuitry can pull it up to the TTL high level.

The Low Emission Current (LEC) monitor, pin 14, is a TTL compatible output signal that indicates the emission current state. If the Series 919 Controller detects LEC, the monitor will be at a TTL high level. The filament and degas power will automatically be disabled to protect the system. LEC can indicate operation at too high of a pressure, operation above the protection pressure, or a broken filament.

Relay Inductive Loads and Arc Suppression

If the set point relays are used to switch inductive loads, e.g., solenoids, relays, transformers, etc., the arcing of the relay contacts may interfere with Controller operation or reduce relay contact life. Therefore an arc suppression network, shown schematically below, is recommended. The values of the capacitance C and the resistance R are calculated by the equations,

$$C = I^2 / (1 \times 10^7) \text{ and } R = E / I^a$$

where,

C is in farads

R is in ohms

I is DC or AC_{peak} load current in amperes

E is DC or AC_{peak} source voltage in volts

$a = 1 + (50/E)$ in volts⁻¹.

Note that,

$$R_{min} = 0.5 \Omega \text{ and } C_{min} = 1.0 \times 10^{-9} \text{ F.}$$

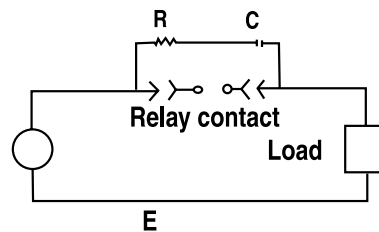

Relay arc suppression network

Operating the Series 919 Hot Cathode System



Be sure Controller power is off before plugging or unplugging a cable to the Sensor.

Connecting or disconnecting cables while the Controller is on may damage the Sensor.

Reading Pressure

Turn the *Power* and *Filament* switches on and depress the *Pressure Display Function* push-button to measure and display pressure and to operate the set points. The graph on the following page shows the Series 919 Hot Cathode System's output voltage as a function of pressure for nitrogen.



When using the graph, remember that the pressure scale is logarithmic, and the voltage scale is linear. Equal increments of distance along the pressure scale do not correspond to equal pressure changes.

Using the Analog Output

Pin 11 of the *Accessory* connector is connected to the analog output signal. This signal has a range of 1 to 9 V (1 V per decade) and is proportional to the logarithm of pressure. It follows the voltage-versus-pressure curve shown on the next page. The analog signal can be used to record data or as input to an automatic pressure controller.

The analog output is 1 V at 1.0×10^{-10} Torr and 9 V at 1.0×10^{-2} Torr. When the Sensor filament is off, the output is 0 V.

Equation for Converting Voltage to Pressure

The following equations convert the Series 919 Controller's voltage output V to a pressure reading P , or vice versa, when using air or nitrogen. The voltage must be within the domain of the equation or an incorrect reading will result.

$$P = 10^{(V-K)}$$

$$V = \log_{10}(P) + K$$

where,

P is in Torr, mbar, or Pascal (depending on K)

V is in volts

$K = 11.000$ for Torr, 10.875 for mbar, or 8.875 for Pascal.

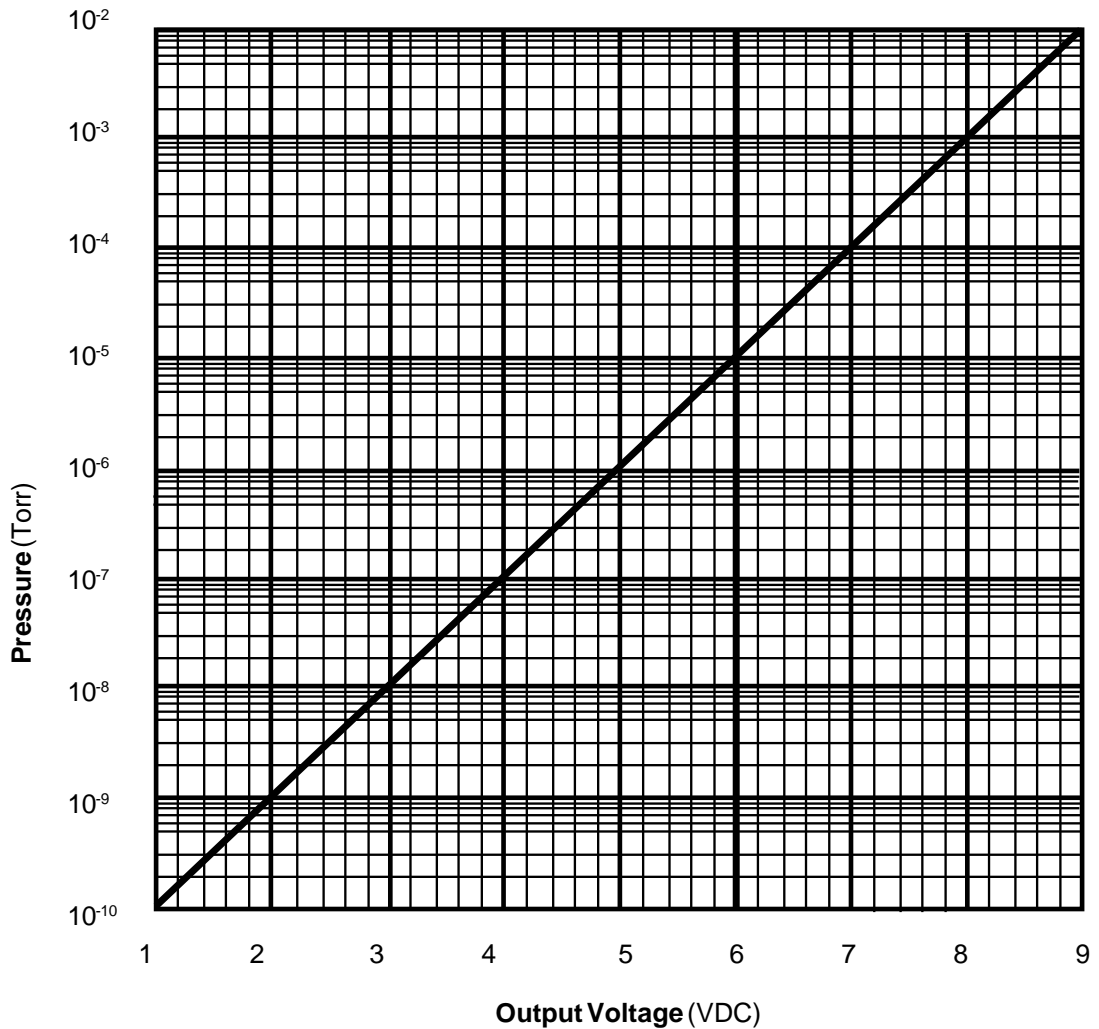

Adjusting the Set Points

The Series 919 Controller has two, independently adjustable set points that can be used throughout its operating range. LEDs indicate when the set points are active. When the power is turned off, the set points remain unchanged.

To adjust a set point to open or close the relay contact at a particular pressure,

- 1 Depress the set point push-button, *SP1* or *SP2*, on the front panel. See figure at left.
- 2 Using a small screwdriver, adjust the corresponding potentiometer until the display reading coincides with the desired set point pressure.
- 3 Repeat this process for the other set point if desired.

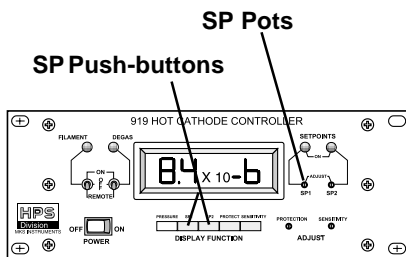

Front Panel

When an LED is on, the measured pressure is below the set point value, the normally open relay contact is closed, and the normally closed contact is open. When an LED is off, the measured pressure is above the set point value, the normally open relay contact is open, and the normally closed contact is closed.

To prevent the relays from oscillating when the pressure passes by a set point pressure, the circuit incorporates hysteresis, so that the set point turns off at a pressure slightly higher than one at which it turns on. The response time of the relays depends upon the pressure at which the Controller is operating.

Adjusting the Filament Protection Limit

The life of the filament can be greatly extended if it is shut off at higher pressures. The lower the pressure at which the filament is shut off, the longer the life will be. The Series 919 Controller has a filament protection feature which automatically shuts off the filament. The protection level can be set between 10^{-6} and 10^{-2} Torr.

To adjust the protection level to a particular pressure,

1. Depress the *Protect* push-button on the front panel below the display.
2. Use a small screwdriver to adjust the *Protection* potentiometer on the front panel, as shown to the right, until the display shows the pressure at which you would like to shut off the filament.

Restarting the Filament

If a pressure value for filament protection has been set and the pressure rises above this value, the filament will shut off automatically. If the pressure falls back below this value, the filament will not turn on automatically. You must restart the filament with either one of the following methods.

Local Method

1. Switch the *Filament* toggle off.
2. Switch it back on.

Remote Method

1. With the *Filament* toggle set to remote, allow pin 10 (filament remote-enable) of the *Accessory* connector to go to a TTL high level if not already high.
2. Return to a TTL low level or ground.

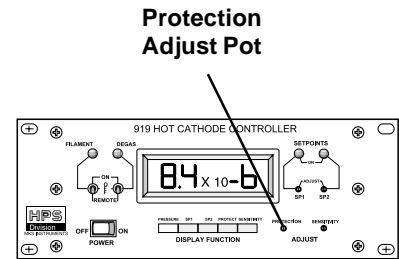

Front Panel

Setting the Sensor Sensitivity

The ion current obtained at a given pressure and electron emission current depends upon the sensor design. The sensor sensitivity S is defined by the equation,

$$S = \frac{i_i}{(i_e \times P)}$$

where,

i_i is ion current in amperes

i_e is electron emission current in amperes

P is pressure in Torr.

The sensitivity for the Series 919 System's Low Power Nude Sensor is about 9 Torr⁻¹ for nitrogen or air. Sensitivity values for other gases differ (see **Using the Series 919 System with Other Gases**, p. 35).

To set the Series 919 System sensitivity,

1. With Controller power on, depress the *Sensitivity* push-button (shown to the left) on the front panel.
2. With a small screwdriver, adjust the *Sensitivity* potentiometer until the display indicates the Sensor's sensitivity value as specified by its manufacturer (e.g. 9.0 x10 0 for the Series 919 Low Power Nude Sensor).

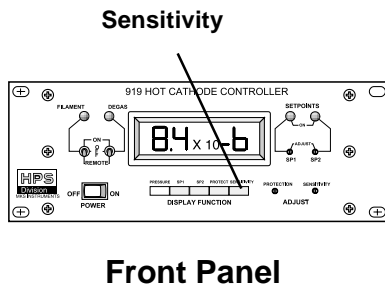

Sensor Sensitivity for Different Pressure Units

Series 919 Controllers displaying units in Torr are shipped with the sensitivity set to 9 Torr⁻¹. Series 919 Controllers that display pressure in units of Pascal or mbar must have the sensitivity divided by 1.33 to read the correct pressure. These Controllers are shipped with a sensitivity of 6.8. The $\times 100$ scale factor between Pascal and mbar units is changed in the Controller electronics.

Example: If a sensor's nominal sensitivity is 12 Torr⁻¹, divide 12 by 1.33 to get 9. Set the Controller to a sensitivity of 9.0 x10 0 for Pascal or mbar units.

Degassing the Sensor

The Series 919 System is designed for I²R degas to remove adsorbed gas from the Sensor. Degas power decreases as cable length increases. Pressure can still be measured during degas.



Degas the Sensor only when the pressure is below 5×10^{-5} Torr.

To degas the Sensor,

1. Turn both the Controller power and the *Filament* toggle on.
2. Switch the *Degas* toggle on to begin degas. The LED above the switch will light up.



Do not degas for more than 2 hours.

3. When degas is complete, switch the *Degas* toggle off.

Degas will work and stay on as long as the filament is on. If the filament goes off, degas will turn off automatically, even though the *Degas* switch is on. To restart degas, the filament must be turned on again.

To control degas with an external device, such as a computer or remote switch, set the *Degas* switch to remote to transfer control to the *Accessory* connector. Refer to **Accessory Connector** on page 28.

Preparing for Sensor Bakeout

The Sensor can be baked with a suitable heating jacket, heating tape, or an oven. With a CF flange, bake to a maximum temperature of 300°C, and with an elastomer-sealed KF flange, bake to a maximum of 150°C.

To prepare the Sensor for bakeout, remove the filament/grid and ion current cables. The connector must be disconnected. Keep the Sensor in vacuum during bakeout.

Using the Series 919 Hot Cathode System with Other Gases

A hot cathode ionization sensor measures pressure by the degree of ionization of a gas, so the pressure reading depends on the type of gas in the system. The Series 919 System is calibrated to read pressure for air or nitrogen.

Unless calibrated otherwise, the Series 919 System displays a pressure for other gases corresponding to the equivalent degree of ionization of nitrogen. This pressure reading is the *nitrogen equivalent pressure* of the gas, and it can be higher or lower than the true gas pressure, depending upon the ionization characteristics of the gas at that pressure. Air calibration is indistinguishable from nitrogen.

The Series 919 Controller can be calibrated to directly indicate pressures of gases other than air or nitrogen. The relative sensitivity of the gas measured is multiplied by the Sensor's nitrogen sensitivity. The sensitivity range is between 4 and 50 Torr⁻¹.

Adjusting System Sensitivity for Another Gas

To adjust the sensitivity control for direct pressure reading of gases other than nitrogen,

Calculate the sensitivity S with the following equation:

$$S = S_r \times S_{\text{sensor}}$$

where,

S_r is the sensitivity of the gas used relative to nitrogen

S_{sensor} is the sensitivity of the sensor used (e.g., 9 Torr⁻¹ for Series 919 System's Hot Cathode Low Power Nude Sensor).

Rough values of the relative sensitivities for various gases are shown in the table on the next page.

To determine more precisely the *nitrogen equivalent pressure* or the direct pressure reading of gases, it is necessary to calibrate the Series 919 System with the gas to be measured. This calibration requires a direct pressure sensor such as a spinning rotor gauge to act as the calibration standard.

Depress the *Sensitivity* push-button on the Controller front panel, and adjust the *Sensitivity* potentiometer until the calculated value is displayed.

Sensitivities Relative to Nitrogen		
<i>Gas</i>	<i>Symbol</i>	<i>Sensitivity (S_t)</i>
Air		1.00
Argon	Ar	1.29
Carbon Dioxide	CO ₂	1.42
Deuterium	D ₂	0.35
Helium	He	0.18
Hydrogen	H ₂	0.46
Krypton	Kr	1.94
Neon	Ne	0.30
Nitrogen	N ₂	1.00
Nitrogen Oxide	NO	1.16
Oxygen	O ₂	1.01
Sulfur Hexafluoride	SF ₆	2.50
Water	H ₂ O	1.12
Xenon	Xe	2.87

Maintaining the Series 919 Hot Cathode System

Cleaning the Controller Front Panel

The Series 919 Controller front panel is designed to resist most laboratory solvents. It can be cleaned with water or isopropyl alcohol.



Do not use acetone on the front panel.

Servicing the Controller

The Series 919 Controller is designed to be maintenance-free under normal operation. If a problem should occur, the following chart lists symptoms, possible causes, and their remedies. With this guide, you should be able to diagnose some problems and correct them. Those which fall outside the scope of this chart are generally not serviceable by the user, and the unit should be returned to HPS® for repair.

Replacing a Power Fuse

To change a Controller fuse,

1. Unplug the power cord from the Controller.
2. Insert a screwdriver blade under the tab to the left of the voltage display on the line input connector and twist the screwdriver to remove the cover and expose the fuse holders.
3. Pull a fuse holder (marked with a white arrow) out and remove a fuse.
4. Install the correct fuse, as indicated in the table below.
5. Replace the fuse holder into the line input connector, and close the power connector door.

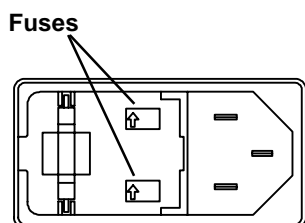

**AC power
connector with
fuse box**

Voltage, Range Fuse (V)	Voltage, (V)	Nominal (A)
90 to 110	100	T 1.25
110 to 130	120	T 1.00
210 to 230	220	T 0.63
230 to 250	240	T 0.50

Troubleshooting Chart

Symptom	Possible Cause	Remedy
No indication on display.	<ol style="list-style-type: none"> 1. Controller not plugged into proper power source. 2. Power switch off. 3. Power fuse blown. 4. Defective power supply PC board. 5. Pressure is out of the Controller's range. 6. Defective, broken, or disconnected ion current or filament/grid cable. 7. Broken filament. 	<ol style="list-style-type: none"> 1. Verify power source and plug it in to the correct one. 2. Turn power on. 3. Replace fuse. 4. Return to HPS® for repair. 5. Controller will not read above 10^{-2} Torr. 6. Replace cable. 7. Replace Sensor.
Fuse blows repeatedly.	<ol style="list-style-type: none"> 1. Power source with incorrect voltage. 2. Incorrect fuse rating. 3. Defective power supply PC Board. 	<ol style="list-style-type: none"> 1. Use correct voltage or change Controller voltage setting. 2. Insert correct fuse (refer to p. 37). 3. Return to HPS® for repair.
Pressure reading is inaccurate.	<ol style="list-style-type: none"> 1. Pressure out of the Controller's measurement range. 2. Sensor interference from external magnetic field. 3. Sensor needs degassing. 4. Controller out of calibration. 5. Gas in system not air or nitrogen. 6. Degas on. 7. Controller set to wrong sensitivity. 	<ol style="list-style-type: none"> 1. Range is 10^{-2} to 10^{-10} Torr. 2. Remove magnetic field source. 3. Degas following the procedure on p. 33. 4. Return to HPS® for service. 5. Set sensitivity for gas used (refer to p. 35) 6. Turn degas off. 7. Change sensitivity for sensor type.
Degas does not turn on.	<ol style="list-style-type: none"> 1. Pressure above the set protection level. 2. Open grid circuit in Sensor or cable. 3. Filament switch not on. 	<ol style="list-style-type: none"> 1. Lower pressure before degas. 2. Replace Sensor or cable. 3. Turn filament switch on.
Pressure readings are too low or too high.	<ol style="list-style-type: none"> 1. Sensor cable not connected. 2. Contaminated Sensor. 3. Current leak across dirty insulators inside Sensor. 	<ol style="list-style-type: none"> 1. Check cable connection. 2. Replace Sensor. 3. Replace Sensor.

Testing the Sensor

The Series 919 System's Hot Cathode Low Power Nude Sensor contains filament, grid, and collector electrodes. Test the Sensor with an ohmmeter. There should be no shorts between the electrodes and the vacuum chamber or the Sensor body.

Accessories

Part #

Accessory Connector Kit	100005087
-------------------------	------------------

Cable for the Low Power Nude Sensor, Molded Connectors

10 ft (3.0 m)	100006953
25 ft (7.6 m)	100006954
50 ft (15.2 m)	100006955
Custom	100006956

Sensor, Low Power Nude

Mounting Hardware Kit, Half-rack	100005651
----------------------------------	------------------

Nipple, 2 $\frac{3}{4}$ " CF, with Screen	100883069
---	------------------

Power Cord, 115 VAC	103150001
---------------------	------------------

<i>HPS® Series 919 Hot Cathode Ionization High Vacuum Sensor User's Manual</i>	109190098
--	------------------

Please call HPS® Customer Service Department at 1-303-449-9861 or 1-800-345-1967 to order any of these parts or to receive catalogs for other HPS® Products.

Product Warranty

Extent of the Warranty

MKS Instruments, HPS® Product, Inc. (HPS®), warrants the HPS® Series 919 Hot Cathode Ionization High Vacuum Sensor System and its accessories to be free from defects in materials and workmanship for one (1) year from the date of shipment by HPS® or authorized representative to the original purchaser (PURCHASER). Any product or parts of the product repaired or replaced by HPS® under this warranty are warranted only for the remaining unexpired part of its one (1) year original warranty period. After expiration of the applicable warranty period, the PURCHASER shall be charged HPS® current prices for parts and labor, plus any transportation for any repairs or replacement.

ALL EXPRESS AND IMPLIED WARRANTIES, INCLUDING THE IMPLIED WARRANTIES OF MERCHANTABILITY AND FITNESS FOR A PARTICULAR PURPOSE, ARE LIMITED TO THE WARRANTY PERIOD. NO WARRANTIES, EXPRESS OR IMPLIED, WILL APPLY AFTER THIS PERIOD.

Warranty Service

The obligations of HPS® under this warranty shall be at its option: (1) to repair, replace, or adjust the product so that it meets applicable product specifications published by HPS® or (2) to refund the purchase price.

What Is Not Covered

The product is subject to above terms only if located in the country of the seller from whom the product was purchased. The above warranties do not apply to:

- I. Damages or malfunctions due to failure to provide reasonable and necessary maintenance in accordance with HPS® operating instructions.
- II. Damages or malfunctions due to chemical or electrolytic influences or use of the product in working environments outside the specification.
- III. Fuses and all expendable items which by their nature or limited lifetime may not function for a year. If such items fail to give reasonable service for a reasonable period of time within the warranty period of the product; they will, at the option of HPS®, be repaired or replaced.
- IV. Defects or damages caused by modifications and repairs effected by the original PURCHASER or third parties not authorized in the manual.

Condition of Returned Products

HPS® will not accept for repair, replacement, or credit any product which is asserted to be defective by the PURCHASER, or any product for which paid or unpaid service is desired, if the product is contaminated with potentially corrosive, reactive, harmful, or radioactive materials, gases, or chemicals.

When products are used with toxic chemicals, or in an atmosphere that is dangerous to the health of humans, or is environmentally unsafe, it is the responsibility of the PURCHASER to have the product cleaned by an independent agency skilled and approved in the handling and cleaning of contaminated materials before the product will be accepted by HPS® for repair and/or replacement.

In the course of implementing this policy, HPS® Customer Service Personnel may inquire of the PURCHASER whether the product has been contaminated with or exposed to potentially corrosive, reactive, harmful, or radioactive materials, gases, or chemicals when the PURCHASER requests a return authorization. Notwithstanding such inquiries, it is the responsibility of the PURCHASER to ensure that no products are returned to HPS® which have been contaminated in the aforementioned manner.

Other Rights and Remedies

- I. These remedies are exclusive. HPS® SHALL NOT BE LIABLE FOR CONSEQUENTIAL DAMAGES, FOR ANTICIPATED OR LOST PROFITS, INCIDENTAL DAMAGES OR LOSS OF TIME, OR OTHER LOSSES INCURRED BY THE PURCHASER OR BY ANY THIRD PARTY IN CONNECTION WITH THE PRODUCT COVERED BY THIS WARRANTY, OR OTHERWISE. Some states do not allow exclusion or limitation of incidental or consequential damage or do not allow the limitation on how long an implied warranty lasts. If such laws apply, the limitations or exclusions expressed herein may not apply to PURCHASER.
- II. Unless otherwise explicitly agreed in writing, it is understood that these are the only written warranties given by HPS®. Any statements made by any persons, including representatives of HPS®, which are inconsistent or in conflict with the terms of the warranty shall not be binding on HPS unless reduced to writing and approved by an authorized officer of HPS®.
- III. This warranty gives PURCHASER specific legal rights, and PURCHASER may also have other rights which vary from state to state.
- IV. For HPS® products sold outside of the U.S., contact your MKS representative for warranty information and service.

Warranty Performance

To obtain warranty satisfaction, contact the following: MKS Instruments, HPS® Division, Inc., 5330 Sterling Drive, Boulder, CO 80301, USA, at phone number (303) 449-9861. You may be required to present proof of original purchase.

Appendix A: How the Series 919 Hot Cathode System Works

Theory of a Hot Cathode Ionization Sensor

Hot cathode ionization sensors use thermionic electrons, electrons emitted from a hot filament, to create ions in a defined volume. In their passage from the cathode through the gas volume, the electrons collide with gas atoms or molecules to form ions. The number of gas molecules ionized depends on the energy of the ionizing electrons, typically about 150 eV, and the ionization probabilities of the constituent gases. The total amount of ionization is related to the molecular concentration. The ions are accelerated to a collector electrode, where they create a current in a circuit, which includes an electrometer. The measured current is proportional to the gas density, which in turn is directly related to the pressure, provided that other parameters like temperature are held constant. The response to pressure changes in such a device is virtually instantaneous.

The Bayard-Alpert sensor design uses a fine wire collector located in the center of a grid, as opposed to the previous large area collectors. Because of its smaller area, fewer x-rays hit the collector, and the sensor can measure pressures to much lower levels, sometimes to below 10^{-10} Torr. This is typically the most popular sensor design for high vacuum measurement. Bayard-Alpert sensors are available in tubed glass envelopes or mounted on elastomer or metal sealed flanges (nude).

A glass envelope sensor tends to be favored because of its low cost and limited thermal and photo effects on the vacuum system. A nude sensor, on the other hand, has the advantage of giving more representative pressure measurements and faster response to pressure changes, because the sensing portion of the sensor is located within the vacuum system and experiences its true pressure, without sensor pumping or outgassing effects.

HPS® Sensors

HPS® offers low power, nude sensors with either a yttria-coated iridium or a tungsten filament, mounted on a 2¾" CF or KF 40 flange. Yttria-coated iridium filaments greatly extend sensor life and minimize damage caused by high oxygen partial pressures or accidental exposure to the atmosphere. They have the further advantage of operating at lower temperatures than tungsten filaments, thereby giving a lower chemical reaction rate and minimizing thermal interference with other equipment. For operation at pressures below 10^{-9} Torr, sensors with tungsten filaments have the advantage of lower internal outgassing rates.

The accuracy of pressure measurements is dependent upon electrical leakage currents. The Series 919 Controller is compatible with most manufacturer's Bayard-Alpert sensors designed for I²R degas.

Notes

The Series 919 Hot Cathode System Design Overview

Circuit Description

This section is intended to give the reader an overview of the internal workings of the Series 919 Controller. This manual does not provide sufficient detail to allow component level troubleshooting of the instrument. Refer to the figure below, the system block diagram, while reading this section.

The Series 919 Controller is an analog instrument with a digital display, which has circuits to control the hot cathode sensor and uses signals from the sensor to display pressure, operate the process control relays, and supply analog voltage vs. pressure output.

Filament Supply

The filament or cathode is heated by an AC transformer winding that is pulse-width-modulated by a triac to regulate the filament temperature, which in turn determines the electron emission current. The pulse-width modulation is achieved by a proportional integral (PI) servo loop that compares the measured electron emission current to a reference voltage determined by the sensitivity setting as set by the user. The servo signal is then compared to a saw tooth oscillator that is synchronized with the AC line frequency. The triac is fired at the appropriate phase angle to control the filament power.

The emission current is 1 mA when the pressure is below 1×10^{-4} Torr and 100 mA when the pressure is above 8×10^{-5} Torr. In the pressure range of 8×10^{-5} to 1×10^{-4} Torr, the emission is 100 mA or 1 mA, dependent upon whether the pressure is increasing or decreasing, respectively. This prevents unstable pressure readings in this transition region.

The filament or cathode bias is developed across a zener diode by the emission current. It is a nominal +30 V referenced to ground and -150 V referenced to the grid.

Degas Supply

The degas supply is a transformer that is energized by a relay when the degas function is enabled by the front panel switch or through the rear panel *Accessory* connector. The filament switch must be on or the Remote Filament Enable pin on the *Accessory* connector must be in a TTL low state, and the system must be at a suitable pressure, before the degas will engage.

Grid Supply

The grid supply is a linear DC supply that consists of a transformer winding, bridge rectifier, a filter capacitor, and voltage regulator. The voltage is regulated by a zener diode and pass transistor. A current limiting circuit keeps the output of the grid supply from exceeding 3 mA, in case there is a short circuit in the sensor or cable. The grid supply is disabled when the filament is off, so that no high voltage is present on the sensor, except when the sensor is in operation. The grid voltage is a nominal +180 V referenced to ground.

Electrometer

The electrometer is a logarithmic current to voltage converter used to measure the sensor ion current. This electrometer has a dynamic range wide enough to cover the entire pressure range with no electronic range changing.

Signal Processing

Taking the output from the log electrometer, inverting it, and summing it with a reference voltage generates the logarithmic output. The output is 1 V per decade of pressure. The reference is 1×10^{-11} Torr for an output of 0 V, but it should be noted that the Controller can not actually measure this low of a pressure.

The analog signal from the electrometer is fed to a 12 bit dual slope integrating analog-to-digital (A/D) converter. The A/D converter integrated circuit is driven by a crystal controlled clock. The A/D converter is also used to measure the set point voltages, overpressure shutdown setting, and the sensitivity setting, dependent upon which front panel display switch is pushed.

Display

The data bits from the A/D converter go to an EPROM that controls the segment drivers for the LED displays. The data from the EPROM is multiplexed between the two mantissa and the two exponent digits. The most significant digit of the exponent can only be either blank or 1, which is commonly referred to as a one and a half digit exponent.

Set Points

The output from the electrometer also goes to the set point comparators. These compare the pressure voltage to the set point voltages as set by the user and activate the process control relays when the pressure is below the set point values. When the pressure rises above the values, the set points are deactivated.

