



## **HPS™ Products**

### **HPS™ Products Series 45**

Vacuum Line Heaters

# ***OPERATION AND MAINTENANCE MANUAL***

---

**Please Note:**

MKS Instruments provides these documents as the latest version for the revision indicated. The material is subject to change without notice, and should be verified if used in a critical application.





## **HPS™ Products**

### **HPS™ Products Series 45**

Vacuum Line Heaters

**March 1997**  
PART #100009448 REV. A

---

Part # 45\_\_ - \_\_\_\_\_ or 95 \_\_\_\_ - \_\_\_\_\_

Please fill in these numbers and have them readily available when calling for service or additional information.

(The part number is located on the label attached to a cable of the heater.)

For more information or literature, contact:

MKS Instruments, Inc., HPS™ Products Inc.  
5330 Sterling Drive  
Boulder, CO 80301 USA

**Phone:** 303-449-9861  
800-345-1967

**FAX:** 303-442-6880

© 1999 MKS Instruments, Inc. HPS™ Products Inc. All rights reserved.

Teflon is a registered trademark of E.I. du Pont de Nemours & Co.  
Twist-Lock is a registered trademark of Hubbell, Inc.  
trademark of MKS Instruments, INC. HPS™ Products Inc.

---

# ***Table of Contents***

Table of Contents	
Package Contents .....	1
Symbols Used in this Manual .....	1
Safety Precautions .....	2
Specifications .....	3
Feature and Control Locations .....	4
Typical Applications for the Series 45 Vacuum Line Heaters .....	5
About the HPS™ Products Series 45 Vacuum Line Heaters .....	6
Installing and Using the Series 45 Vacuum Line Heaters .....	7
Before Installing Heaters .....	7
Power .....	7
Power Cord .....	7
Inspect Pipe System and Heaters .....	7
Installing the Heaters .....	8
Temperature Control Circuit .....	9
Using the Heaters .....	9
Replacing a Blown Fuse in the Power Cord (without GFELCI) .....	10
Accessories / Part Replacement .....	11
Product Warranty .....	12
Notes .....	13



---

# Package Contents

Before unpacking your HPS™ Products Series 45 Vacuum Line Heater, check all surfaces of the packing material for shipping damage.

Please be sure that your Series 45 Heater package contains these items:

- ◆ Series 45 Heaters (quantity specified on packing slip)
- ◆ 1 CE Declaration of Conformity
- ◆ 1 HPS™ Products Series 45 Vacuum Line Heaters User's Guide.



**Power cords are not included with the Heaters and must be ordered separately. See page 10 for a list of these and other accessories.**

Inspect the Heater for visible evidence of damage during shipment. If it has been damaged, notify the carrier immediately. Keep all shipping materials and packaging for claim verification. Do **not** return the product to HPS™.



If any items are missing from the package, call HPS™ Customer Service at 1-303-449-9861 or 1-800-345-1967.

Inspect for visible evidence of damage. If it has been damaged in shipping, notify the carrier immediately. Keep all shipping materials and packaging for claim verification. Do **NOT** return the product to HPS™

## Symbols Used in this Manual

The first two symbols below, that may be located on your Series 45 Vacuum Line Heater, identify critical safety concerns. They are used throughout this manual to further define the safety concerns associated with the product. The last two symbols identify other information in this manual that is essential or useful in achieving optimal performance from the Heater.



**CAUTION:** Risk of electrical shock. ISO3864, No.B.3.6



**CAUTION:** Refer to manual. ISO3864, No.B.3.1 Failure to heed message could result in personal injury or serious damage to the equipment or both.



Failure to heed message could result in damage to the equipment.



Calls attention to important procedures, practices, or conditions.

---

# Safety Precautions



***Do not use Heaters outdoors or in an explosive environment.***

---

The Heaters are rated IP40 according to IEC 529 "Degrees of Protection Provided by Enclosures," (IP Code). IP40 is, "Protected against ingress of solid foreign objects greater than or equal to 1.0 mm in diameter and not protected against ingress of water with harmful effects."



***Heaters are designed for use with metal piping.***

---

Heater operating temperatures may exceed the melting point of other materials. Check specifications.



***Do not immerse the Heaters in water or liquid of any kind.***

---

Electrical shock may result. Permanent Heater damage may also occur.



***Ground piping system according to U.S. National Electric Code or local requirements or both.***

---

If Heaters are used or operated on ungrounded metal piping, a risk of electrical shock is posed. Alternatively, a Ground Fault Equipment Leakage Current Interrupter (GFELCI) may be used.



***Heaters must be secured to piping before operation.***

---

Heaters may overheat, resulting in permanent damage, if not attached to piping. Also, Heaters should only be used with piping of their assigned diameter.

---

# Specifications

<b>Environment</b>	Indoor use only	
<b>Temperature</b>		
<b><i>Heater Nominal Set Point</i></b>	<b>150°C (302°F)</b>	<b>105°C (221°F)</b>
<b><i>Heater Exterior Range</i></b>	60° to 70°C (140° to 158°F)	45° to 55°C (113° to 131°F)
<b><i>Pipe Line Interior Range</i></b>	130° to 170°C (266° to 338°F)	90° to 120°C (194 to 248 °F)
<b>Relative Humidity</b>	90% maximum	
<b>Electrical Duty Cycle</b>	~50% for 120 VAC, ~72% for 100 VAC	
<b>Power Cord Current Limit</b>	12 A	
<b>Materials</b>	Molded silicone foam, fiberglass reinforced silicone, Teflon® insulated wire	
<b>Foam Thickness</b>	0.5 in. (12.7 mm)	
<b>Connectors</b>	Midget Twist-Lock®, nylon, NEMA ML-1	
<b>Weight Range</b>	0.5 to 3.3 lb (0.73 to 1.5 kg)	
<b>Product Safety</b>	CE Mark 89/336/EEC EMC Directive 73/23/EEC LV Directive UL Recognized File E52951 2JR	

---

Design and/or specifications subject to change without notice.

---

# Feature and Control Locations

- ❶ Exterior Heater Surface
- ❷ Interior Heater Mat
- ❸ Control Block with a Ceramic-Bodied, Snap-Action Thermostat and a Thermal Fuse (Out of View)
- ❹ Cable Lead with Male Twist-Lock® Connector
- ❺ Cable Lead with Female Twist-Lock® Connector
- ❻ Nylon-capped Metal Snaps

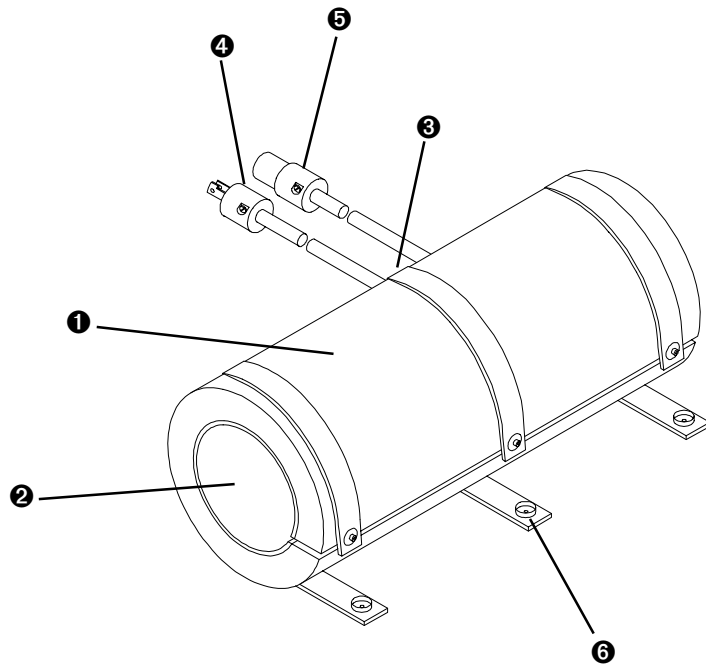

***Straight-Section Heater***

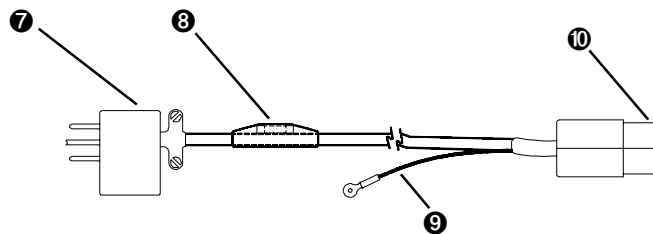

***120 VAC Power Cord  
6 ft or Custom Length, without GFELCI***

- ❷ 120 VAC, Fused Power Plug
- ❸ Spare Fuse
- ❹ Ground Ring Terminal
- ❺ Female Twist-Lock® Connector

---

# Typical Applications for the Series 45 Vacuum Line Heaters

- ❖❖ ***Prevent solidification of ammonium chloride*** ( $\text{NH}_4\text{Cl}$ )  
in a silicon nitride LPCVD system
- ❖❖ ***Prevent solidification of aluminum chloride*** ( $\text{AlCl}_3$ )  
in an aluminum etching system
- ❖❖ ***Reduce solid buildup in other semiconductor processes,***  
such as titanium nitride, tungsten, and TEOS CVD

---

# About the HPS™ Products Series 45 Vacuum Line Heaters

The HPS™ Products Series 45 Vacuum Line Heaters, a line of heating jackets specially made for HPS™ components and valves, have been designed for semiconductor processes to prevent solid buildup in vacuum systems while emphasizing personnel safety. The Series 45 Heaters are designed to be simple and quick to install.

These Heaters reduce contamination, increase your system uptime and product yield, and decrease scheduled maintenance.

To control the solidification of by-products, such as ammonium chloride, you need to maintain a system vacuum component temperature of at least 120°C. The Series 45 Heaters heat your system to a stable temperature well above this minimum, drastically reducing by-product buildup and system downtime, while achieving a low outside temperature, meeting today's stricter corporate personnel safety standards.

The Series limits the outside temperature to 70°C while heating lines internally to an average, stable temperature of 150°C (for the 150°C set point thermostat) or 105°C (for the 105°C set point thermostat). From room temperature, the Heaters typically reach their set temperature in less than 30 minutes.

The Heater's elastic, conforming shape and convenient snaps make installation and removal fast and easy.

All materials used in the Heaters and Insulators are suitable for clean room use.

As a safety feature, a thermal fuse is included, which prevents any possible overheating in the unlikely event of thermostat failure.

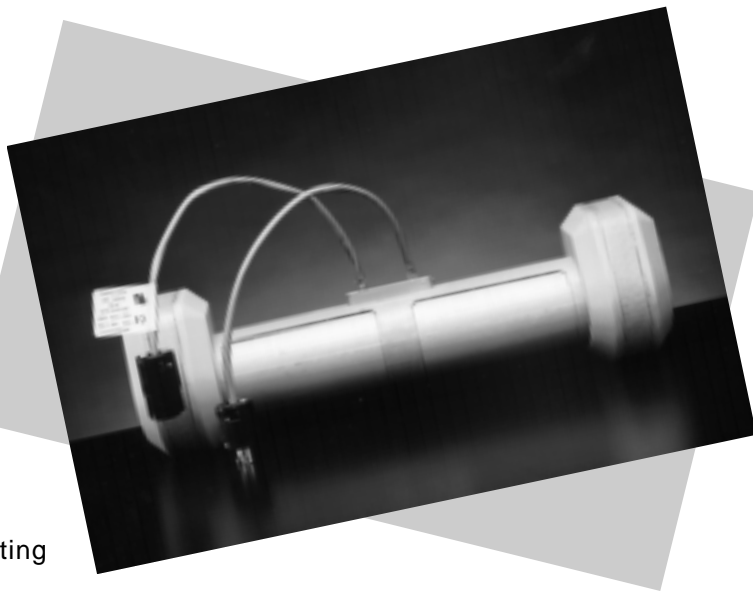

---

# Installing and Using the Series 45 Vacuum Line Heaters

## Before Installing Heaters

### Power

Assigned to each individual Heater is a current rating. Do *not* link Heaters together in excess of 12 A as this may damage the Heaters permanently. Verify load with the following steps.

- 1 Locate the current rating for 120 VAC on the label attached to a cable lead.
- 2 Add the values together to get a total demand of 12 A or less.



***The power and current ratings are different if using a 100 VAC outlet. Add the values shown on the label for 100 VAC.***

Also note that the electrical duty cycle is higher at 100 VAC, meaning Heaters will take longer to reach a stable temperature.

### Power Cord

Using a Ground Fault Equipment Leakage Current Interrupter (GFELCI) is highly recommended. Circuit interruption can be supplied either by your electrical service box or by the HPS GFELCI power cord (see **Accessories**, p. 12). The cord provides a resettable, 12-ampere circuit breaker.

An HPS™ Heater power cord and a separate, portable GFCI are also available (see **Accessories**, p. 12). The power cord has an integrated, replaceable 12-ampere fuse for safety.

Either power cord has a grounded ring terminal for attachment to either ISO-KF or ISO-MF vacuum flange clamps. Place the ring terminal under the wing nut of a standard ISO-KF clamp to ground its flange. A special ISO-Universal Grounding Claw Clamp is available to ground MF 80 or MF 100 clamps to their flange (see **Accessories**, p. 12).

### Inspect Pipe System and Heaters

- 1 Inspect the surfaces of piping for burrs that might penetrate the Heater insulation and for surface defects that may not allow full contact of the Heater or Insulator with the pipe.
- 2 Inspect each Heater for damage, particularly on the ends and the inside surface. Do not use a damaged Heater.
- 3 Contact the HPS™ Customer Service Department if any damage is found.

---

## Installing the Heaters



**Do not use Heaters outdoors or in an explosive environment.**

- 1 At the point of power supply for the Heaters, begin to install them one at a time and fasten in place with their snaps.

Series 45 Heaters are designed to fit snugly for good heat transfer but should snap in place easily. Only moderate insulation compression is needed. Do not use any other device to hold a Heater in place.



***Heaters for bellows and flexible hose are designed for a loose fit to allow for modest bellows and hose movement. These Heaters must be installed with the control block (cord strain relief) in the up position with respect to gravity. Failure to follow these instructions could lead to overheating and possible Heater damage.***

- 2 Wrap and secure Insulators around flanges. Correctly-sized flange Insulators must be used for bellows or hose installation. Special flange Insulators are available for covering connections from tubing to hose.
- 3 Connect all subsequent cable Twist-Lock® connectors.

Arrange and connect Heater cable leads in a manner least likely to place stress on the Heater mounting system or to impair the view of critical readouts. Cables should not touch surfaces that might damage the wire insulation.

The last Heater of each line will have an unused cable with a female connector. It is safe to leave this connector alone. A cap is not required.

- 4 Retrace Heater installation to be sure that all connectors are interlocked and all snaps are securely fastened.



***Ground piping system according to U.S. National Electric Code (NEC) or local requirements or both.***

---

## Temperature Control Circuit



For specially ordered Heaters that need external temperature control, continue on with the next step. For standard catalog Heaters with internal mechanical thermostats, skip this section. Go to Using the Heaters.

- 1 Turn off power to the controller if it has been turned on.
- 2 Connect any thermocouple circuit to its respective temperature controller.
- 3 Verify power supply from the controller to the Heater. It must be properly fused per manufacturer's specification, local code, and NEC requirements.
- 4 Connect the power supply and ground leads from the temperature controller to the initial Heater.
- 5 Adjust the temperature control to the desired setting.



***Do not exceed 180°C. A higher temperature setting may shorten Heater life.***

## Using the Heaters



***Heaters must be secured to piping before operation.***

Upon start-up, observe Heaters closely for smoke, which indicates overheating of piping or an individual Heater.

- 1 If smoke is seen, shut down the system.
- 2 Verify that operating temperatures are under 180°C before restarting.
- 3 Check the Heaters' rated voltage. It must be consistent with the supply voltage.



***When installed in confined areas, some of the outside surface of a Heater may reach temperatures higher than 80°C.***

Touching these Heaters will not cause harm due to the thermal insulation properties of the Series 45 Heaters, which prevent excessive energy transfer.

---

## Replacing a Blown Fuse in the Power Cord (without GFELCI)

The power cords' integrated 12-ampere fuse is located inside the 120 VAC plug. The fuse may blow if Heaters are strung together in excess of 12 A. A shorted Heater would also blow a fuse. Observe or test the Heater and check power consumption before replacing.

- 1 With a screwdriver, remove the rubber insulator sheet at the base of the electrical prongs of the plug as shown to the right. A pry slot has been provided to ease removal.
- 2 A spare fuse is encapsulated in the power cord near the plug. Use a knife to gently pry it out.
- 3 Insert the new fuse into the plug of the cord and replace rubber insulator sheet.

If another fuse is needed, replace with a fuse rated for 12 A and 100 to 250 V. Spare fuses may also be purchased from HPS (see **Accessories**, p. 12).

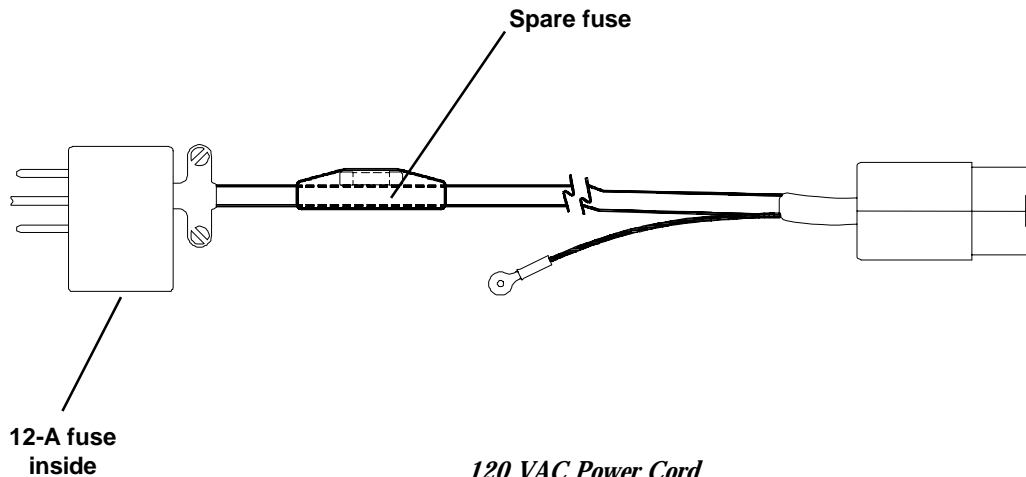

*120 VAC Power Cord  
6 ft or Custom Length, without GFELCI*

---

# Accessories / Part Replacement

	<i>Part #</i>
<b>Fuses</b>	
12 A, Box of 5	100006985
<b>Ground Fault Circuit Interrupter (GFCI)</b>	43PWRACC001
<b>Grounding Claw Clamp</b> MF 80 or MF 100	100007322
<b>Low Temperature Alert (LTA) Jumper Kit</b>	100008683
<b>LTA Lead Kit</b>	100008680
<b>Power Cord, 120 VAC</b>	
6 ft	43PWRCORD01
Custom, 25 ft Max	43PWRCORD02
6ft, With GFELCI (and 12-Ampere Circuit Breaker)	43PWRCORD04

Please call HPS™ Customer Service Department at either 1-303-449-9861 or 1-800-345-1967 to order any of these parts or to receive catalogs for other HPS™ products.

---

# Product Warranty

## Extent of the Warranty

MKS Instruments, Inc., warrants the HPS™ Products warrants the HPS™ Products Series 45 Vacuum Line Heaters and its accessories to be free from defects in materials and workmanship for one (1) year from the date of shipment by HPS™ or authorized representative to the original purchaser (PURCHASER). Any product or parts of the product repaired or replaced by HPS™ under this warranty are warranted only for the remaining unexpired part of its one (1) year original warranty period. After expiration of the applicable warranty period, the PURCHASER shall be charged HPS™ current prices for parts and labor, plus any transportation for any repairs or replacement.

ALL EXPRESS AND IMPLIED WARRANTIES, INCLUDING THE IMPLIED WARRANTIES OF MERCHANTABILITY AND FITNESS FOR A PARTICULAR PURPOSE, ARE LIMITED TO THE WARRANTY PERIOD. NO WARRANTIES, EXPRESS OR IMPLIED, WILL APPLY AFTER THIS PERIOD.

## Warranty Service

The obligations of HPS™ under this warranty shall be at its option: (1) to repair, replace, or adjust the product so that it meets applicable product specifications published by HPS™ or (2) to refund the purchase price.

## What Is Not Covered

The product is subject to above terms only if located in the country of the seller from whom the product was purchased. The above warranties do not apply to:

- I. Damages or malfunctions due to failure to provide reasonable and necessary maintenance in accordance with HPS operating instructions.
- II. Damages or malfunctions due to chemical or electrolytic influences or use of the product in working environments outside the specification.
- III. Fuses and all expendable items which by their nature or limited lifetime may not function for a year. If such items fail to give reasonable service for a reasonable period of time within the warranty period of the product; they will, at the option of HPS™, be repaired or replaced.
- IV. Defects or damages caused by modifications and repairs effected by the original PURCHASER or third parties not authorized in the manual.

## Condition of Returned Products

HPS™ will not accept for repair, replacement, or credit any product which is asserted to be defective by the PURCHASER, or any product for which paid or unpaid service is desired, if the product is contaminated with potentially corrosive, reactive, harmful, or radioactive materials, gases, or chemicals.

When products are used with toxic chemicals, or in an atmosphere that is dangerous to the health of humans, or is environmentally unsafe, it is the responsibility of the PURCHASER to have the product cleaned by an independent agency skilled and approved in the handling and cleaning of contaminated materials before the product will be accepted by HPS™ for repair and/or replacement.

In the course of implementing this policy, HPS™ Customer Service Personnel may inquire of the PURCHASER whether the product has been contaminated with or exposed to potentially corrosive, reactive, harmful, or radioactive materials, gases, or chemicals when the PURCHASER requests a return authorization. Notwithstanding such inquiries, it is the responsibility of the PURCHASER to ensure that no products are returned to HPS™ which have been contaminated in the aforementioned manner.

## Other Rights and Remedies

- I. These remedies are exclusive. HPS™ SHALL NOT BE LIABLE FOR CONSEQUENTIAL DAMAGES, FOR ANTICIPATED OR LOST PROFITS, INCIDENTAL DAMAGES OR LOSS OF TIME, OR OTHER LOSSES INCURRED BY THE PURCHASER OR BY ANY THIRD PARTY IN CONNECTION WITH THE PRODUCT COVERED BY THIS WARRANTY, OR OTHERWISE. Some states do not allow exclusion or limitation of incidental or consequential damage or do not allow the limitation on how long an implied warranty lasts. If such laws apply, the limitations or exclusions expressed herein may not apply to PURCHASER.
- II. Unless otherwise explicitly agreed in writing, it is understood that these are the only written warranties given by HPS™. Any statements made by any persons, including representatives of HPS™, which are inconsistent or in conflict with the terms of the warranty shall not be binding on HPS™ unless reduced to writing and approved by an authorized officer of HPS™.
- III. This warranty gives PURCHASER specific legal rights, and PURCHASER may also have other rights which vary from state to state.
- IV. For HPS™ products sold outside of the U.S., contact your MKS™ representative for warranty information and service.

## Warranty Performance

To obtain warranty satisfaction, contact the following: MKS™ Instruments, Inc., HPS™ Products, Inc., 5330 Sterling Drive, Boulder, CO 80301, USA, at phone number (303) 449-9861. You may be required to present proof of original purchase.

---

# Notes





