

# MKS Type 152F Exhaust Valve Controller

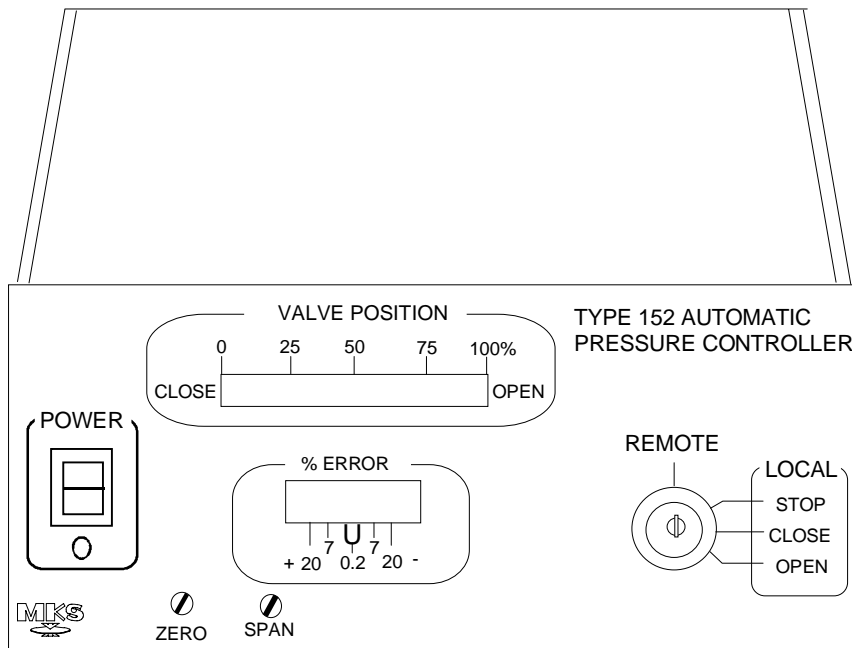

**Please Note:**

MKS Instruments provides these documents as the latest version for the revision indicated. The material is subject to change without notice, and should be verified if used in a critical application.

*Copyright © 1995 by MKS Instruments, Inc.*

*All rights reserved. No part of this work may be reproduced or transmitted in any form or by any means, electronic or mechanical, including photocopying and recording, or by any information storage or retrieval system, except as may be expressly permitted in writing by MKS Instruments, Inc.*

Baratron® is a registered trademark of MKS Instruments, Inc., Andover, MA.

---

## Table of Contents

Safety Procedures and Precautions.....	1
Chapter One: General Information.....	3
Introduction .....	3
A Typical Control System .....	3
How The Type 152 Controller Works.....	4
How This Manual is Organized.....	5
Terminology.....	5
Customer Support.....	6
Chapter Two: Installation .....	7
How To Unpack the Type 152 Controller.....	7
Unpacking Checklist .....	7
Companion Products.....	8
Product Location and Requirements.....	9
General Requirements .....	9
Setup .....	10
Using Diffusion Vacuum Pumps .....	10
Interconnections .....	11
Additional Requirements for High Accuracy Systems .....	13
Configuring The Type 152 Controller Initially .....	14
Chapter Three: Overview.....	15
Front Panel Controls.....	15
Valve Position.....	15
Mode Switch.....	15
Error.....	16
Power.....	16
Zero .....	16
Span.....	16
Rear Panel Controls .....	17

Input Connector .....	18
Connections .....	18
Interface Connector.....	19
Connections .....	20
AC Power Connector .....	20
Voltage Selection Switch .....	20
10V/1V Selector .....	21
Valve Connector .....	21
Fuse.....	22
Caution .....	22
Phase Lead Control.....	22
Gain Control.....	22
Position Control .....	23
How Position Control Works .....	23
Valve Position Commands.....	23
Valve Slip Indicator .....	24
Valve Position Output .....	25
How Valve Position Output Works .....	25
How To Set the Valve Speed on the PC/VPO Board .....	25
The Extended Range Option .....	27
Manual Operation: Using External Commands.....	28
Valve Position Commands.....	28
Softstart Mode .....	29
How To Change the Input Range .....	30
Position Control.....	30
Calculating the Maximum Rate of Pressure Rise .....	31
Chapter Four: Operation .....	33
How To Control the Valve Manually.....	33
Driving the Valve to a Specific Position.....	33
How To Tune the Type 152 Controller .....	34
Preparing the System .....	34
Classic Tuning Method .....	35
Alternate Tuning Method.....	35

---

How To Change the Response Switch Setting .....	36
How To Select a Set Point Value .....	37
How To Adjust the Zero .....	37
How To Adjust the Span.....	38
Chapter Five: Remote Zero and Valve Position Output Option.....	39
Remote Zero.....	39
How To Use the Remote Zero.....	40
The Overrange Output .....	40
Valve Position Output.....	41
How Valve Position Output Works.....	41
How To Set the Valve Speed on the RZ/VPO Board .....	42
Chapter Six: RS-232 Communications Option.....	45
Initial Communication Parameters.....	45
RS-232 Connector .....	46
How To Change the Communication Parameters .....	47
The Internal/External Set Point .....	50
Operation.....	51
Wake-Up.....	51
RS-232 Commands.....	52
Instruction Commands .....	52
Data Sent From the 152 Controller to the Computer .....	54
Errors .....	55
RS-232 Buffer Size .....	55
Appendix A: Product Specifications .....	57
Index.....	59



## List of Figures

Figure 1: Interconnections for a Typical System .....	11
Figure 2: Interconnections for a High Accuracy System.....	13
Figure 3: Front Panel Controls on the 152 Controller .....	15
Figure 4: The Error LED Indicator Lights.....	16
Figure 5: Rear Panel Controls on the 152 Controller.....	17
Figure 6: Differential Inputs on the Input Connector.....	18
Figure 7: External Set Point Connection on the Interface Connector .....	20

## List of Tables

Table 1: Cables for Recommended Pressure Transducers.....	12
Table 2: Input Connector Pin Assignments.....	18
Table 3: Interface Connector Pin Assignments.....	19
Table 4: Valve Connector Pin Assignments.....	21
Table 5: Fuse Information .....	22
Table 6: Position Control Voltages.....	23
Table 7: Switch Configuration for Valve Speed.....	26
Table 8: Switch Configuration for Valve Full Scale Counts.....	27
Table 9: Extended Range Option .....	27
Table 10: Summary of the External Commands for Valve Action.....	29
Table 11: Applied Voltage and the Corresponding Set Point.....	37
Table 12: Switch Configuration for Valve Speed Setting .....	43
Table 13: Switch Configuration for the Valve Full Scale Counts .....	43
Table 14: RS-232 Communication Parameters.....	45
Table 15: RS-232 Connector Pin Assignments .....	46
Table 16: RS-232 Switch 1 Configuration .....	48
Table 17: RS-232 Switch 2 Configuration .....	49
Table 18: RS-232 Instruction Commands .....	52
Table 19: Data Sent From the 152 Controller .....	54



## **Safety Procedures and Precautions**

### **DO NOT SUBSTITUTE PARTS OR MODIFY INSTRUMENT**

Do not install substitute parts or perform any unauthorized modification to the instrument. Return the instrument to an MKS Calibration and Service Center for service and repair to ensure that all safety features are maintained.

### **SERVICE BY QUALIFIED PERSONNEL ONLY**

Operating personnel must not remove instrument covers. Component replacement and internal adjustments must be made by qualified service personnel only.

### **GROUNDING THE PRODUCT**

This product is grounded through the grounding conductor of the power cord. To avoid electrical shock, plug the power cord into a properly wired receptacle before connecting it to the product input or output terminals. A protective ground connection by way of the grounding conductor in the power cord is essential for safe operation.

### **DANGER ARISING FROM LOSS OF GROUND**

Upon loss of the protective-ground connection, all accessible conductive parts (including knobs and controls that may appear to be insulating) can render an electrical shock.

### **GROUND AND USE PROPER ELECTRICAL FITTINGS**

Dangerous voltages are contained within this instrument. All electrical fittings must be of the type specified, and in good condition. All electrical fittings must be properly connected and grounded.

### **USE THE PROPER POWER CORD**

Use only the power cord and connector specified for your product.  
Use only a cord in good condition.

### **USE THE PROPER POWER SOURCE**

This product is intended to operate from a power source that does not apply more than 250 Volts RMS between the supply conductors, or between either of the supply conductors and ground. A protective ground connection by way of the grounding conductor in the power cord is essential for safe operation.

**USE THE PROPER FUSE**

Use only a fuse of the correct type, voltage rating, and current rating, as specified for your product.

**DO NOT OPERATE IN EXPLOSIVE ATMOSPHERES**

To avoid explosion, do not operate this product in an explosive atmosphere unless it has been specifically certified for such operation.

Definitions of WARNING, CAUTION, and NOTE messages used throughout the manual.

**Warning**

---

The **WARNING** sign denotes a hazard. It calls attention to a procedure, practice, condition, or the like, which, if not correctly performed or adhered to, could result in injury to personnel.

---

**Caution**

---

The **CAUTION** sign denotes a hazard. It calls attention to an operating procedure, practice, or the like, which, if not correctly performed or adhered to, could result in damage to or destruction of all or part of the product.

---

**Note**

---

The **NOTE** sign denotes important information. It calls attention to a procedure, practice, condition, or the like, which is essential to highlight.

---

## Chapter One: General Information

### Introduction

The Type 152F Exhaust Valve Controller works with the Type 253 Exhaust Valve to maintain a constant pressure in a process chamber by varying the pumping speed. The 152 controller provides  $\pm 15$  VDC power output and accepts the pressure input from a variety of pressure transducers.

The 152 controller determines the position of the 253 valve based on the actual pressure of the process chamber compared to the desired, or set point, temperature. The set point can be defined by an external analog signal, or, when the RS-232 Interface option is installed, a remote signal sent from an external computer. You can issue digital commands to control the valve action and force the valve to open, close, or stop, and to initiate the softstart mode.

The standard 152 controller is configured for Position Control/Valve Position Output (PC/VPO) control in addition to the normal pressure control. The *Position* Control mode controls the position of the valve relative to an external set point. The normal *Pressure* Control mode positions the valve based on the pressure of the system, relative to an external set point. The PC/VPO mode can be replaced with the optional Remote Zero/Valve Position Output (RZ/VPO) mode. The RZ/VPO option allows you to remotely zero the 152 controller.

The RS-232 Interface option adds RS-232 communication capabilities to the 152 controller. This option allows you to select the mode of operation, and to control the valve directly, using serial communications.

### **A Typical Control System**

The 152 controller is used in a wide variety of control systems, however, several characteristics are common in most control systems. Typically, the control system consists of three basic parts:

- The pressure sensor or transducer
- The controller and the control valve
- The pressure system (whose pressure is being controlled)

The pressure sensor or transducer is normally a MKS Baratron<sup>®</sup> capacitance manometer whose output is 0 to 10 VDC. The pressure system consists of a process chamber and a pumping system. Normally, a mass flow controller regulates the flow of gas entering the system, while the 152 controller and the 253 valve maintain the system pressure.

## How The Type 152 Controller Works

The 152 controller reads the DC pressure transducer signal, compares it to a predefined set point, and places the valve in a position to maintain, or achieve, the set point pressure. The controller utilizes the most widely accepted form of controller action; Proportional, Integral, Derivative, or PID control. The 152 controller uses the following PID equation:

$$\text{Signal to Valve} = P(E) + \int(E)dt + D(dE/dt)$$

### The Error

The error is defined as:

$$\text{Error} = \text{Set Point} - \text{Actual Reading}$$

When the actual pressure reading is less than the set point value, the error term is a positive value. Therefore, the signal to the valve increases to close the valve. As the valve closes, less gas is pumped out of the process chamber, so the pressure rises. Eventually, the pressure rises to meet the set point value.

When the actual pressure reading exceeds the set point value, the error term is a negative value. Therefore, the signal to the valve decreases to open the valve. As the valve opens, the pressure in the system is reduced because more gas is pumped out of the process chamber. Eventually, the pressure decreases to meet the set point value.

### Note



---

The action of the valve is reversed when the Normal/Reverse switch on the PC board is in the Reverse position. The default setting is Normal.

---

The front panel of the 152 controller has an Error indicator that displays the error.

### The Proportional Term

The proportional term is a linear function of the error signal. The Gain control adjusts the proportional term. Typically, a higher gain setting yields the most accurate control.

### The Derivative Term

The derivative term is proportional to the rate of change of the error signal (up to some maximum value). The Phase Lead control adjusts the derivative term.

The derivative term anticipates the effect of the valve action on the system. It acts to achieve the set point pressure with minimal overshoot or undershoot. The effect of the derivative term is to cancel out the build-up of lags inherent in the system.

### The Integral Term

The integral term is proportional to the length of time that the error signal exists. Therefore, as time passes, the integral term acts to position the valve to reduce the error signal to zero.

## **How This Manual is Organized**

This manual is designed to provide instructions on how to set up and install a Type 152 unit.

**Before installing your Type 152 unit in a system and/or operating it, carefully read and familiarize yourself with all precautionary notes in the *Safety Messages and Procedures* section at the front of this manual. In addition, observe and obey all WARNING and CAUTION notes provided throughout the manual.**

Chapter One, *General Information*, (this chapter) introduces the product and describes the organization of the manual.

Chapter Two, *Installation*, explains the environmental requirements and describes how to mount the instrument in your system.

Chapter Three, *Overview*, gives a brief description of the instrument and its functionality.

Chapter Four, *Operation*, describes how to use the instrument and explains all the functions and features.

Chapter Five, *Remote Zero and Valve Position Control Option*, details the features included with this option.

Chapter Six, *RS-232 Communications Option*, outlines the RS-232 communications protocol and features provided by the optional RS-232 interface.

Appendix A, *Product Specifications*, lists the specifications of the instrument.

### **Terminology**

The term “transducer” is used throughout the manual to describe the pressure measuring device, although the 152 controller can work with either transducers or sensors. Strictly speaking, a transducer converts the voltage signal into a pressure reading and outputs the actual pressure value, whereas a sensor outputs the raw voltage reading to a signal conditioner which converts the voltage reading into the pressure value.

## **Customer Support**

Standard maintenance and repair services are available at all of our regional MKS Calibration and Service Centers in North America, Europe, Israel, Japan, Korea, and Taiwan. In addition, MKS accepts the instruments of other manufacturers for recalibration using the Primary and Transfer Standard calibration equipment located at all of our regional service centers. Should any difficulties arise in the use of your Type 152 instrument, or to obtain information about companion products MKS offers, contact any authorized MKS Calibration and Service Center. If it is necessary to return the instrument to MKS, please obtain an ERA Number (Equipment Return Authorization Number) from the MKS Calibration and Service Center before shipping. The ERA Number expedites handling and ensures proper servicing of your instrument.

Please refer to the inside of the back cover of this manual for a list of MKS Calibration and Service Centers.

---

### **Warning**



**All returns to MKS Instruments must be free of harmful, corrosive, radioactive, or toxic materials.**

---

## Chapter Two: Installation

### How To Unpack the Type 152 Controller

MKS has carefully packed the Type 152 unit so that it will reach you in perfect operating order. Upon receiving the unit, however, you should check for defects, cracks, broken connectors, etc., to be certain that damage has not occurred during shipment.

---

**Note**

Do *not* discard any packing materials until you have completed your inspection and are sure the unit arrived safely.

---

If you find any damage, notify your carrier and MKS immediately. If it is necessary to return the unit to MKS, obtain an ERA Number (Equipment Return Authorization Number) from the MKS Service Center before shipping. Please refer to the inside of the back cover of this manual for a list of MKS Calibration and Service Centers.

#### Unpacking Checklist

##### Standard Equipment:

- The 152 controller
- Power cord
- Key

The 152 controller includes a Position Control/Valve Position Output control board, unless you order the optional Remote Zero/Valve Position Output board.

##### Optional Equipment:

- Remote Zero/Valve Position Output board (in place of the Position Control/Valve Position Output board)
- 152F-K1 Electrical Connector Accessories Kit (contains the appropriate connectors for you to make your own cables)
- RS-232 communications
- CB252-2-10 cable to connect the valve to the controller (various lengths are available, call the factory)
- Rack Mounting Kit (RM-6)
- Optional cables for the companion pressure transducers

## **Companion Products**

- Type 253 exhaust valve (to be used in conjunction with the 152 controller)
- Pressure transducers: 121A, 122, 122A/B, 622A, 222A/B, 127A, 227, 227A, 220, 220A, 220B, 124A, 128A, 623A, 624A, 626A, 627A, 628A
- Pressure sensors and signal conditioners: 310/170M-6, 370/270, and the 590A, 690A, 698A, 615, 617, with either the 270 or 670 signal conditioners

## **Product Location and Requirements**

The 152 controller fits in a standard ½ rack and can be placed on a work bench or mounted in an instrument panel. The optional RM-6 Rack Mount Kit is necessary to mount the controller in a panel cutout or a 19” rack.

### **Caution**



---

**Position the Type 152 controller in a location with sufficient air circulation to keep the product within its specified temperature range. Insufficient air circulation could damage the controller.**

---

The 152 controller is designed to withstand ordinary mechanical shock and vibration.

### **General Requirements**

For optimum pressure control, mount the pressure transducer and exhaust valve as close as possible to the process chamber.

- Operating temperature: 0 to 40 ° C (32 to 104° F)
- Power: 90 - 132 VAC @ 50/60 Hz, 180 - 264 VAC @ 50/60 Hz  
60 Watts maximum 132 VAC 50/60 Hz
- Use plastic washers when mounting the controller in a rack mount
- Connect the pressure transducer to the process chamber with ¼ inch diameter tubing (minimum), limited to a length of 6 inches or less

## Setup

The 152 controller works with all sizes of the 253 exhaust valve. The size of the valve required for a system is dictated by the size of the vacuum exhaust line and the range of conductance necessary for the pressure and flow rates involved. (Refer to the 253 data sheet for detailed information on the different valves available.)

When configuring the 152 controller, follow all of the requirements outlined in the *Product Location and Requirements* section on page 9. Mount the exhaust valve and the pressure transducer as close as possible to the process chamber for the best pressure control. Use ¼ inch diameter tubing, maximum length of 6 inches, to connect the pressure transducer to the process chamber. This enhances the stability of the system by eliminating any delays in the system response. If the pressure transducer cannot be located less than 6 inches from the process chamber, use a larger diameter tubing to compensate for conductance losses.

Install an isolation valve, to protect the transducer, if the process chamber will be opened to the atmosphere repeatedly. This is especially important for low range transducers.

Check all fittings for small drilled passages or leaks. Remove or disconnect any unnecessary anti-chambers off of the main process chamber since they may cause stability problems.

## Using Diffusion Vacuum Pumps

Diffusion vacuum pumps experience a condition referred to as “choking” when a large volume of gas is introduced into a system at an excessively high pressure. This causes the pumping speed to change radically. The system becomes unstable and cannot maintain the set point pressure. Often times pneumatic noise makes it impossible to control the system. The only way to regain control of the system is to close down the inlet to the pump.

### Caution



---

**Never operate a diffusion pump at inlet pressures above which the “top jet” will experience a pressure in excess of  $5 \times 10^{-4}$  Torr. Operating under such conditions will cause the pump to fail and may cause irreparable damage.**

---

## Interconnections

Figure 1 shows how to connect a 152 controller to a typical pressure control system. You can use any pressure transducer that delivers 10 Volts full scale in such a system. Refer to Table 1, page 12, for a complete list of the appropriate transducers to use.

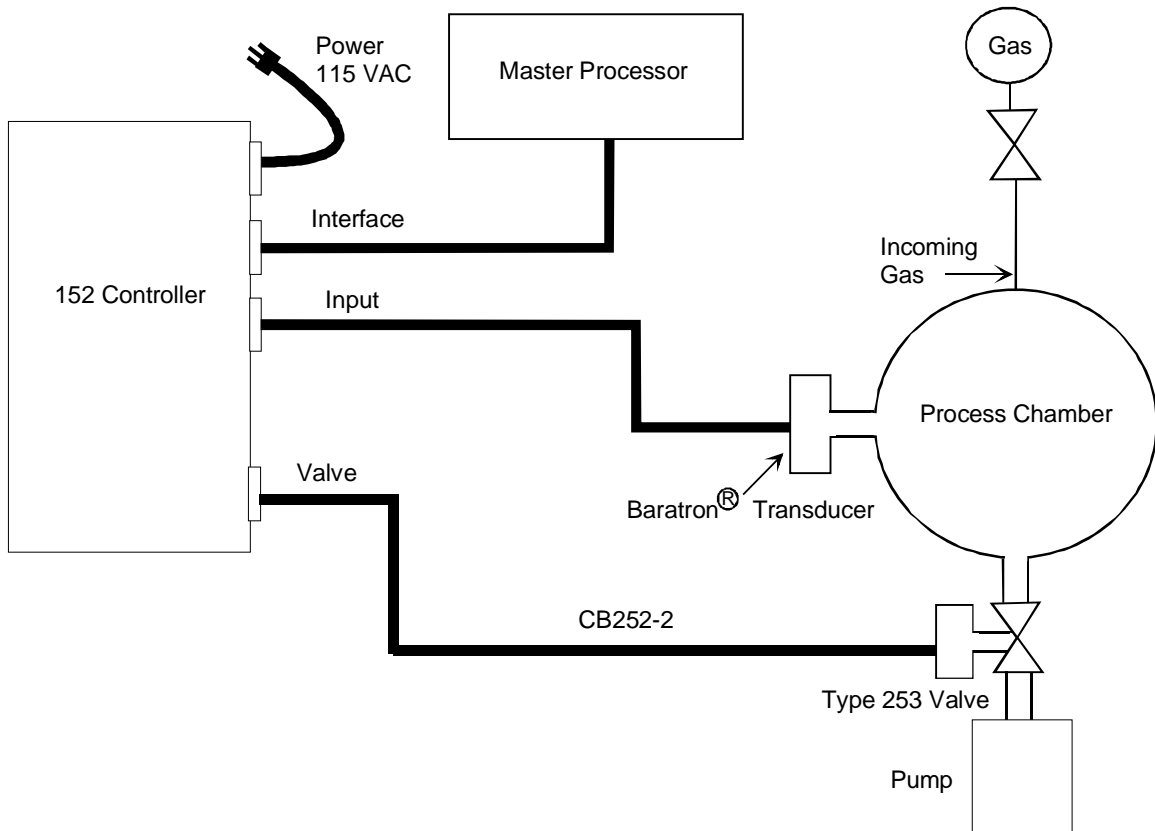

Figure 1: Interconnections for a Typical System

Cables for Recommended Pressure Transducers		
Transducer	Interconnecting Cable	Full Scale Output Voltage
310/170M-6*	CB-250-6	10 V
370/270 or 670*	CB-250-7	10 V
128, 625, 628†	CB-128-2	10 V
220	CB-254-4	10 V
121, 221	CB-254-1	10 V
122 or 222A/B	CB-254-2	10 V
227, 227A	CB-254-11	10 V
127, 624, 626, 627	CB-258-1	10 V
590, 690, 698 /270 or 670*	CB-250-7-6	10 V
124, 622, 623	CB-254-2	10 V
120 with separate input power connector	CB-120-3	10 V
223	CB-254-2	1 V, 5 V, or 10 V
258, 358, 558	CB-258-1	5 V
615, 616, 617/270 or 670*	CB-270-1	10 V
<i>* indicates a pressure sensor used with a signal conditioner</i>		
<i>† requires an additional power supply</i>		

Table 1: Cables for Recommended Pressure Transducers

**Note**

Use the CB-254-17 cable to connect to a PDR-C-1C/2C, PDR-D-1, or a PDR-5B pressure readout.

### Additional Requirements for High Accuracy Systems

Most systems designed for high accuracy include a pressure sensor and a high accuracy signal conditioner. The 152 controller connects to the high accuracy signal conditioner (Type 270 or 670), which in turn, connects to the pressure sensor. Examples of high accuracy pressure sensors include the 310, 370, 390, 590, 690, 615, 616, 617, and 698.

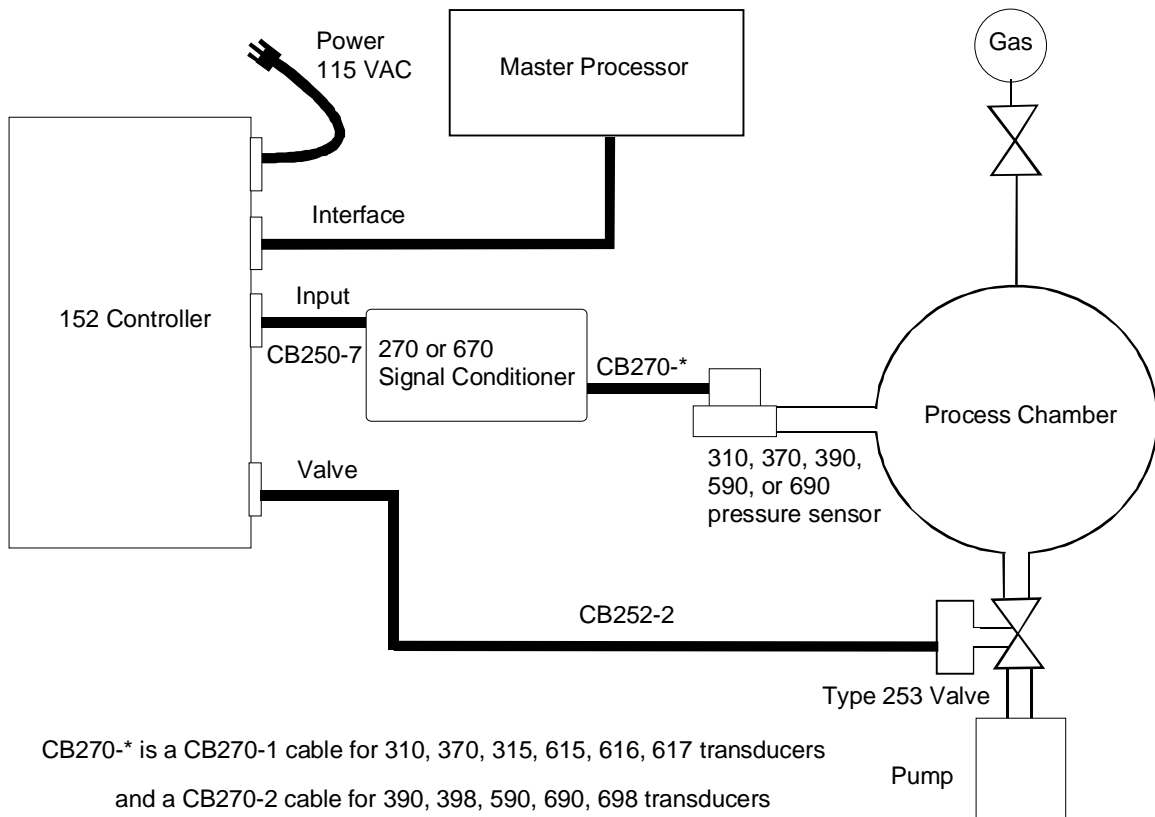

Figure 2: Interconnections for a High Accuracy System

If your system includes 170M-6C or 270 signal conditioner, be sure to place the Response switch (on the 170M-6C or 270) in the Normal position. If your system includes a 670 signal conditioner, set the response entry through the Setup menu.

## **Configuring The Type 152 Controller Initially**

Before you connect the AC line cord, turn the Power Switch Off and check that the voltage selector on the rear panel is in the proper position.

1. Make the following preliminary settings:
  - Gain            100%
  - Phase Lead    3 seconds

The Gain and Phase Lead controls are located on the rear panel. For additional information on the gain setting, refer to the *Gain Control* section on page 22. Refer to the *Phase Lead* section, on page 22, for more information on the phase lead.

2. Plug in the power cord and connect the Input and Interface cables.
3. Turn on the power.

Refer to Figure 3, page 15, for the location of the power switch. The power LED should light.
4. Pump down the process chamber to a pressure less than the resolution of the transducer.

This step may take several hours. Refer to your transducer manual for the appropriate pressure and an estimate of the time required.
5. Zero the transducer by adjusting the front panel zero for a zero reading at pin 2 on the Interface connector. Reference the measurement to pin 8 on the same connector.

## Chapter Three: Overview

### Front Panel Controls

Figure 3 shows the front panel of the 152 controller.

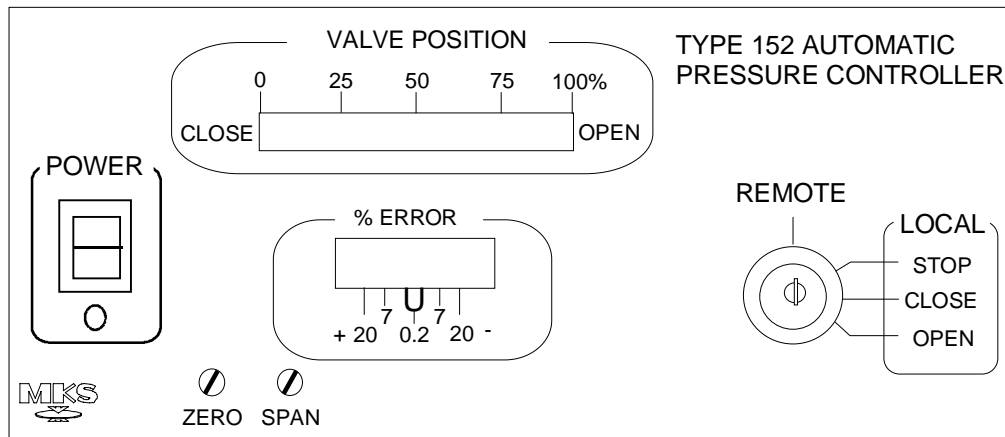

Figure 3: Front Panel Controls on the 152 Controller

#### **Valve Position**

The Valve Position indicator bar displays the position of the valve. The indicator bar shows the valve position as a percent of open, with 0% being fully closed and 100% being fully opened. The bar is divided into 25% increments with a resolution of 5% increments.

#### **Mode Switch**

The Mode Switch selects the mode of operation: Remote or Local. When the key lock switch is in the REMOTE position, the 152 unit can be controlled by a computer. When in the LOCAL mode, you can Open, Close, or Stop the valve directly from the front panel.

## Error

The Error indicator uses LEDs to indicate the value of the error term, used in closed loop control. The error term is the difference between the actual pressure reading and the set point value.

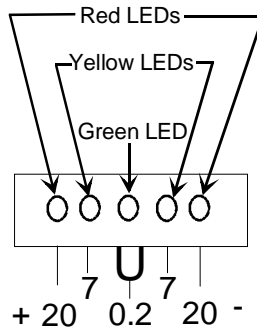

Figure 4: The Error LED Indicator Lights

In the center of the error indicator is a green LED, that illuminates when the error is  $< \pm 0.2\%$  of full scale. The LEDs on either side of the center LED are yellow and indicate the error is  $< \pm 7\%$  of full scale. The outside LEDs are red and indicate the error is  $> \pm 20\%$  of full scale. When the error is  $> \pm 7\%$  but  $< \pm 20\%$ , no LEDs are illuminated.

## Power

The Power switch controls the AC power to the 152 controller. The LED below the switch illuminates when the controller is turned on.

## Zero

Use the Zero potentiometer to compensate for any zero offset in the transducer. Before adjusting the Zero pot, be sure that the system is pumped down to a pressure below the resolution of the transducer.

## Span

The Span potentiometer enables you to adjust the full scale span of the pressure transducer.

## Rear Panel Controls

Figure 5 shows the location of the controls on the rear panel of the 152 controller.

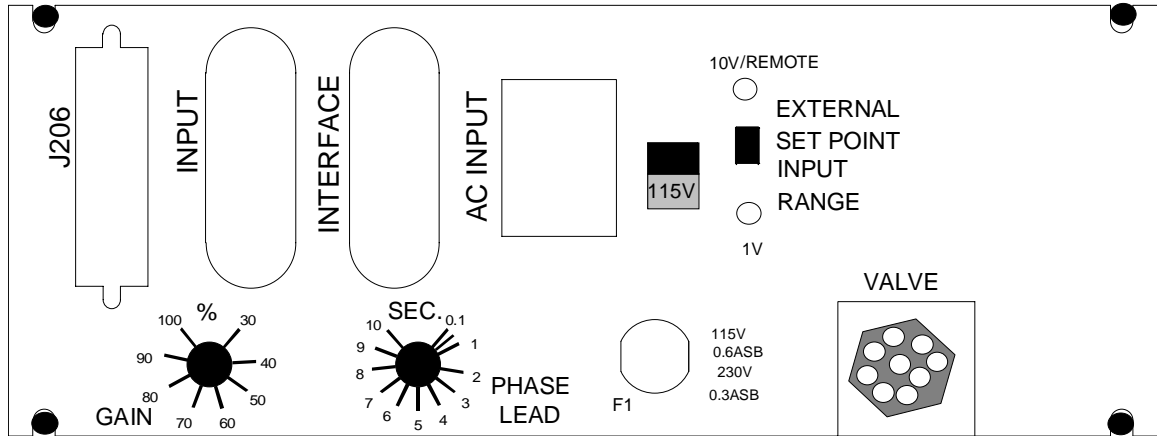

Figure 5: Rear Panel Controls on the 152 Controller

## Input Connector

The Input connector is a 14-pin female ribbon connector. It provides  $\pm 15$  Volt power and accepts the pressure transducer signal.

Input Connector Pin Assignments	
Pin	Assignment
1	+ Input
2	Spare
3	Spare
4	Spare
5	Spare
6	Spare
7	Spare
8	- Input
9	Spare
10	Spare
11	+15 Volt Output
12	Power Supply Ground (Analog Ground)
13	-15 Volt Output
14	Chassis Ground
*Connect the -Input signal (pin 8) to the analog ground (pin 12) at the input source.	

Table 2: Input Connector Pin Assignments

## Connections

The 152 input signal lines are *differential* type inputs. Figure 6 describes how to make the connections.

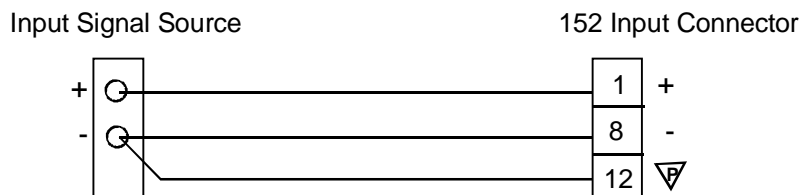

Figure 6: Differential Inputs on the Input Connector

## Interface Connector

The Interface connector is a 14-pin female ribbon connector that provides access to the miscellaneous outputs and external inputs to the controller. Table 3 lists the pin assignments. Refer to the *Manual Operation: Using External Commands* section, beginning on page 28, for a description of the external commands.

<b>Interface Connector Pin Assignments</b>		
<b>Pin</b>	<b>Assignment</b>	<b>Comments</b>
1	+ External Set Point	0 to 5 VDC
2	Pressure Output	0 to 10 VDC
3	Digital Ground	Common to all Select lines
4	Open Select	Connect to Pin 3 to Open valve
5	Close Select	Connect to Pin 3 to Close valve
6	Stop Select	Connect to Pin 3 to Stop valve
7	Softstart Select	Connect to Pin 3 for Softstart
8	Analog Ground	Common for external set point and pressure outputs
9	Position Control Select Remote Zero	with Position Control/VPO board with Remote Zero/VPO option board
10	Position Output *	0 to 10 VDC
11	Valve Slip Overrange indicator	with standard Position Control/VPO board with Remote Zero/VPO option board
12	Power Supply Ground	Analog Ground
13	1 VDC Range Input**	Connect to Pin 3 for 1 VDC input**
14	Chassis Ground	
<p>* Available with the Position Control/Valve Position Output only</p> <p>** The input range switch on the rear panel must be set in the 10 V, Remote position</p>		

Table 3: Interface Connector Pin Assignments

### Connections

The 152 external set point input is single-ended and uses the analog ground (pin 8) as the ground or (-) input. Figure 7 shows the proper connections.

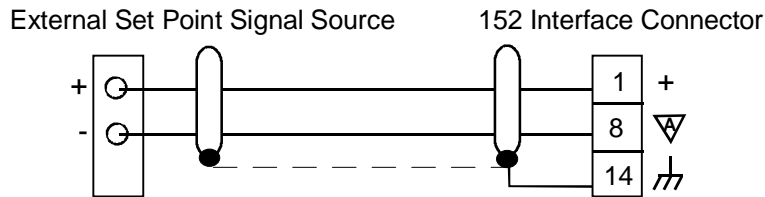

Figure 7: External Set Point Connection on the Interface Connector

### AC Power Connector

The AC Power connector is located on the rear panel of the 152 controller, and accepts 115/230 VAC power.

### Voltage Selection Switch

The Voltage Selection switch configures the 152 controller to accept either 115 or 230 VAC input voltage.

#### Caution



**The Voltage Selection switch on the 152 controller must be set to the proper input voltage *before* you connect the power cord and turn on the power. Otherwise, the controller will be severely damaged.**

Use a blunt instrument, such as a flat head screw driver, to change the position of the switch.

### 10V/1V Selector

The 10V/1V Selector switch sets the input full scale voltage at either 10 Volts or 1 Volt. The default setting is 10 Volts full scale. Choose the 1 Volt full scale setting only when you need better resolution *and* the control pressures are less than 10% of full scale of the pressure transducer.

*Example:* If you are using a 1 Torr pressure transducer (10 Volts = 1 Torr) but your set point is less than 100 microns (1 Volt), then select the 1 Volt full scale setting. A full scale set point (5 Volts) would give a control pressure of 100 microns. If you need a set point of 5 microns, the set point voltage must be 0.25 Volts.

$$\frac{5 \text{ microns}}{100 \text{ microns}} \times 5 \text{ Volts} = 0.25 \text{ Volts}$$

### Valve Connector

The Type 253 valve connects to the 152 controller through the Valve connector. Use the CB-252-2 cable to connect the valve to the controller.

Valve Connector Pin Assignments	
Pin	Assignments
A	Winding A
B	Winding A'
C	Winding A Common
D	Winding B
E	Winding B'
F	Winding B Common
H	Close Limit Switch
J	Open Limit Switch
K	Limit Switch Common

Table 4: Valve Connector Pin Assignments

## Fuse

The 152 controller uses a line fuse to protect the internal circuitry. Only the “hot” side of the line is fused. Table 5 lists input voltage and the type of fuse to use.

Fuse Information	
Voltage	Fuse Type
115 VAC	0.6 A Slo Blo
230 VAC	0.3 A Slo Blo

Table 5: Fuse Information

### Caution



**Disconnect the power cord from the 152 controller *before* you replace the fuse, to avoid any damage.**

## Phase Lead Control

The Phase Lead control setting compensates for the major lag inherent in most control systems. In pressure systems, this lag is generally caused by the restrictions in the pump line and the capacity of the pressure vessel. The control ranges from 0.1 to 10 seconds, with typical settings between 1 to 5 seconds. Too low a setting will cause overshoot; too high a setting will cause a slow response.

Refer to the *How To Tune the 152 Controller* section, on page 34, for instructions on setting the phase lead.

## Gain Control

The Gain control setting determines the overall gain of the controller. The higher the gain the lower the deadband associated with the signal. As a general rule, set the gain as high as possible, without sacrificing the stability of the system, to achieve the best possible control.

The *How To Tune the 152 Controller* section, on page 34, discusses how to set the gain.

## **Position Control**

The 152 controller uses the Position Control and Valve Position Output (PC/VPO) board as the standard configuration. The Remote Zero and Valve Position Output (RZ/VPO) board is available as an option. Refer to *Chapter Five, Remote Zero and Valve Position Output Option*, beginning on page 39, for a discussion of the RZ/VPO option.

Position Control (PC) enables the 152 unit to control the position of the throttle valve. Normally, the pressure of the system determines the position of the throttle valve. To activate the PC mode, connect pin 9 (position control select) on the Interface connector to pin 3 (digital ground). Use a TTL, CMOS, relay or switch contact to make the connections. Refer to Table 3, page 19, for a complete description of the pin assignments for the Interface connector.

The 152 controller returns to pressure control when the connection between pin 9 and pin 3 is broken, or when the RS-232 Auto (“D”) command is issued.

### **How Position Control Works**

When the PC mode is activated, the Valve Position Output (VPO) signal becomes the input to the 152 controller. The valve is directed to a position determined by the set point input, either analog or RS-232, rather than the pressure in the system.

In PC mode, a 0.0 Volt set point represents the full open position, and 5 Volt set point represents full close. Set point voltages between 0 and 5 Volts will give valve positions between full open and full closed.

The Valve Position Output is 10 Volts for full open and 0.0 Volts for full close.

<b>Position Control Voltages</b>		
<b>Position</b>	<b>Set Point</b>	<b>Valve Position Output</b>
Full Open	0 V	10 V
Full Close	5 V	0 V

Table 6: Position Control Voltages

### **Valve Position Commands**

The valve position commands, Open, Close, and Stop, override PC mode when commanded. The 152 controller returns to PC mode once the valve position commands are released.

### **Valve Slip Indicator**

The Valve Slip Indicator (VSI) provides a digital output if the stepping motor in the valve does not precisely follow the step commands by the 152 controller. The digital output is available on pin 11 of the Interface connector. The common connection for the digital output is pin 12 (power supply common).

The digital output can be open collector or directly from CMOS (15V) gates. Any one of four different signals can be used as the slip indicator output. Two signals (one positive true, one negative true) are active momentarily (50 to 500  $\mu$ seconds) when the valve hits a limit switch with a slip error greater than 4%. The other two signals are latched true when the valve hits a limit switch with slip error greater than 4%, and stay true until the valve hits a limit switch with slip error less than 4%. When the valve hits the limit switch and there is less than 4% slip error, the output will be false.

The 152 controller (with the standard PC/VPO board installed) is shipped with the digital output connected to the open-collector transistor. If the valve slips, the digital output goes negative true momentarily.

## **Valve Position Output**

The Valve Position Output (VPO) provides a real-time analog signal at pin 10 of the Interface connector. Refer to Table 3, page 19, for the complete list of pin assignments for the Interface connector. This signal is 0 Volts (0%) when the valve is fully closed and 10 Volts (100%) when the valve is fully opened. Since the volume of gas pumped from a vacuum pumping system will be a function of both the valve's position (and therefore, conductance) and the pumping speed, any progressive movement of the valve towards the open position (for the same set point), will indicate a general deterioration in the performance of the pump. You may be able to discern when the pump requires maintenance by observing the position of the valve.

### **How Valve Position Output Works**

When the 152 controller is powered up, the output voltage goes to the position indicated by the valve's limit switches: 0 V for close and 10 V for open. If the valve is not at a limit switch, the Valve Position Output (VPO) is not defined, so the 152 controller cannot track the valve position. At this point, the output voltage will be greater than 10 Volts. When the valve contacts either limit switch, the VPO is defined, so the 152 controller can track the valve position with an output voltage between 0 and 10 Volts.

### **How To Set the Valve Speed on the PC/VPO Board**

The 152 controller is shipped with the VPO set for either the standard or the fast Type 253 valve, depending upon which valve is ordered with the 152 controller. You can configure the controller to operate the other speed valve by changing several switch positions on the PC/VPO board, or, if you have the Remote Zero/Valve Position Output option, on the RZ/VPO board.

---

#### **Warning**



**The 152 controller has lethal voltages inside. Servicing of the unit must be performed by qualified personnel only.**

**To avoid an electrical shock, disconnect the power line *before* opening the unit.**

---

1. Turn off the power to the 152 controller.
2. Disconnect the AC power cord.

---

#### **Caution**



**To avoid damage to sensitive internal components, personnel should be grounded through a safety impedance while working inside the 152 controller, and the unit itself must be static-free.**

---

3. Unscrew the two phillips screws at the rear of the controller and remove the cover.

4. *If you have the Position Control/Valve Position Output configuration:* Locate the PC/VPO board.

*If you have the Remote Zero/Valve Position Output option:* Locate the RZ/VPO board.

Either board is positioned on the connector closest to the center of the controller, adjacent to the ribbon cable connector. If the RS-232 option is installed, its board is positioned along the side panel of the controller.

5. Grasp each end of the board and rock it until it loosens. Lift the board up and out of the unit.
6. Locate the dipswitch bank for Switches 1, 2, and 3.

*On the PC/VPO board:* The switches are located on the right-hand side of the board, when viewed from the component side.

*On the RZ/VPO board:* The switches are located on the far right hand side of the board, when viewed from the component side.

7. Set the switches for the correct valve speed.

Refer to Table 7 for a description of the switch settings.

<b>Valve Speed Switch Settings (S3)</b>		
<b>Switch Pole</b>	<b>Standard</b>	<b>Fast</b>
1	Open	Closed
2	Closed	Open
3	Open	Open
4	Open	Open

Table 7: Switch Configuration for Valve Speed

8. Set Switches 1 and 2 for the correct full scale count for the valve.  
Refer to Table 8 for a description of the switch settings.

<b>Full Scale Count Switch Settings (S1 &amp; S2)</b>			
<b>Dipswitch Pole</b>	<b>Value</b>	<b>Standard</b>	<b>Fast</b>
S1 4	16	C	O
S1 3	32	C	C
S1 2	64	O	O
S1 1	128	O	O
S2 4	256	O	C
S2 3	512	O	O
S2 2	1K	C	C
S2 1	2K	O	C
<i>where C = Closed, O = Open</i>			

Table 8: Switch Configuration for Valve Full Scale Counts

### The Extended Range Option

Switch 4 selects the “Extended Range” option. The default configuration does not employ this option. The extended range option increases the maximum number of counts from 4000 to 13000. Some slower motors are geared down and require more motor steps, or counts, to move from open to close than faster geared motors do. The extended range option is only necessary with special order gate valves.

<b>Extended Range Switch Settings</b>		
<b>Pole</b>	<b>No Extended Range*</b>	<b>Use Extended Range</b>
1	Closed	Open
2	Closed	Open
3	Open	Closed
4	Open	Closed
<i>where Closed = On, Open = Off</i>		
<i>* default configuration</i>		

Table 9: Extended Range Option

---

## Manual Operation: Using External Commands

**Note**

---

The Mode Selection switch must be set for `REMOTE` before any external commands will be acknowledged.

---

The 152 controller will operate in the Automatic mode unless any of the external commands (Open, Close, Stop, Softstart, Position Control, and 1 VDC full scale input) are issued. All of the external commands are accessed through the Interface connector. Refer to Table 3, page 19, for the Interface connector pin assignments. To issue a command, tie the appropriate pin to digital ground (pin 3). The external command lines are internally pulled-up to +5 V with 4.7K resistors and can be selected with a relay contact closure, TTL, 5 V CMOS logic, or an open collector transistor.

### Valve Position Commands

Selecting Open (pin 4) will drive the valve towards the full open position. The valve will continue to open as long as pin 4 is tied to pin 3. When the valve reaches the full open position, it will stop and remain in that position.

Selecting Close (pin 5) will command the controller to drive the valve to the full close position. The valve will stay in the fully closed position as long as Close is commanded.

Selecting Stop (pin 6) or *both* Open (pin 4) and Close (pin 5) will stop the valve. The valve will remain in that position as long as commanded.

**Note**

---

When the 152 controller is connected to a computer, use the external commands to drive the valve to a specific location. Do not use the external set point since the valve may not remain in the desired position. Refer to the *Driving the Valve to a Specific Position* section on page 33, for more information.

---

### Softstart Mode

Selecting Softstart (pin 7) will activate the softstart mode. The softstart mode reduces the speed of the valve to approximately 20% of its maximum speed. Reducing the speed of the valve may be necessary to avoid dramatic pressure changes. (The 20% figure can be adjusted with potentiometer labeled R50 on the main PC board. The potentiometer is located adjacent to the Key Lock switch. ) The 152 controller will operate in the softstart mode until *either* the error signal reverses polarity (as it does when the pressure reaches the set point value) or any one of the other external commands (Open, Close, Stop) are commanded.

To reactivate the softstart mode, reconnect pin 7 to pin 3 (after the signal goes high). The softstart command needs to be on (low) for at least 50 milliseconds and then it must be high for at least 0.25 seconds before the softstart mode is reactivated.

#### Note



If an external command is holding the valve in one position, you must release that external command before the softstart can be activated.

Refer to Table 10 for a summary of the external valve action command.

External Commands Summary				
Open	Close	Stop	Softstart	Controller Action
-	-	-	-	Automatic operation
C	-	-	-	Drives toward Open
-	C	-	-	Drives toward Close
C	C	-	X	Stops
-	-	C	X	Stops
-	-	-	C	Softstart
<i>where: - = not being commanded            C = being commanded            X = does not matter</i>				

Table 10: Summary of the External Commands for Valve Action

### How To Change the Input Range

Selecting the 1 VDC Input Range (pin 13) changes the full scale input from 10 VDC to 1 VDC. The full scale input will be 1 VDC as long as pin 13 is tied to pin 3.

---

**Note**

Be sure that the 10V/1V switch, on the rear panel, is set to the 10 V position. The 152 controller will not accept external commands when the 10V/1V switch is in the 1V position.

---

### Position Control

The 152 controller can provide position control and valve position output with the Position Control/Valve Position board installed. On the Interface connector, connect the Position Control pin (pin 9) to digital ground (pin 3) to select position control. While position control is activated, the set point input determines the position of the valve, not the pressure of the system.

---

**Note**

In Position Control, a 0.0 Volt (0%) set point denotes full open, and 5.0 Volts (100%) denotes full close.

---

## Calculating the Maximum Rate of Pressure Rise

Use the following formula to calculate the maximum rate of rise of pressure:

$$P_r = \frac{F}{V}$$

where:

$P_r$  is the pressure rate of rise, Torr/sec.  
 $F$  is flow in Torr-liters/sec.  
 $V$  is volume in liters

The exhaust valve must be in the fully closed position.

In systems with small input flows and relatively large volumes, the pressure will rise slowly, even when the Type 253 exhaust valve is fully closed.

If you cannot adjust the controller for adequate control, check your system for improper pneumatic connections. Refer to the *Setup* section, beginning on page 10, for more information.

This page intentionally left blank.

## Chapter Four: Operation

### How To Control the Valve Manually

The 152 controller operates in the Automatic Pressure Control mode by default. Use the external commands, accessible through the Interface connector, to control the valve manually or to change to position control. Refer to the *Manual Operation: Using the External Commands* section, on page 28, for additional information.

#### **Driving the Valve to a Specific Position**

When the 152 controller is interfaced with a computer, use the external commands (Open, Close, and Stop) to command the valve to a specific position. While it is possible to drive the valve to one extreme or the other (Open or Close) with the external set point command, the valve *may not remain* in that position.

For example, you enter an external set point of zero to drive the valve to the full open position. The valve moves to the full open position initially, until the pressure approaches the set point value of zero. The 152 controller *anticipates* the pressure reaching the set point value and partially closes the valve to avoid overshooting the set point. The rate of change of pressure is reduced, and may be stopped altogether. This problem occurs most often with high gain or large phase lead settings.

## How To Tune the Type 152 Controller

It is necessary to tune the 152 controller to optimize how it controls your system. There are two tuning methods available, the Classic method and an Alternate method. The classic method requires knowledge of PID control parameters and experience adjusting these parameters. The alternate method yields stable control parameters faster than the classic method.

### Preparing the System

1. Turn on the upstream gas source.
2. Put the 152 controller in Automatic operation.

The 152 controller is in Manual operation if any of the external commands (Open, Close, or Stop) are issued. To return to Automatic operation, release any external commands. The 152 controller is in Automatic operation by default.

3. Set the gain to 100%.

The Gain control is located on the rear panel of the 152 controller.

4. Set the phase lead to 3 seconds.

The Phase Lead control is located adjacent to the Gain control on the rear panel.

5. Select a set point between 0 and 5 Volts.

Refer to the *How To Select the Set Point Value* section, on page 37, for instructions on setting the set point value. The pressure should increase smoothly to the set point value.

---

#### Note



Connecting a chart recorder to the pressure output signal makes the process of tuning the system more visible. The chart recorder displays the under and overshoot response of the system caused by the tuning adjustments.

---

## Classic Tuning Method

1. *If the pressure overshoots the set point:* Increase the phase lead.

Use your experience with PID control parameters as a guide to determine the amount of increase.

*If there is no overshoot and the system is slow to approach the set point:* Reduce the phase lead.

You may need to use a “trial and error” approach to determine the actual reduction in the phase lead setting.

2. Select a new set point to repeat the test.

Refer to the *How To Select the Set Point Value* section, on page 37, for instructions on setting the set point value. This will verify the phase lead.

---

### Note



The appropriate phase lead setting for a rise in pressure normally differs from the appropriate setting for a drop in pressure. Choose a compromise setting that takes into consideration the anticipated pressure profile.

---

3. *If the pressure oscillates about the set point value:* Reduce the gain.

The best pressure control occurs with the highest possible gain, so reduce the gain only as much as is necessary to prevent oscillation.

## Alternate Tuning Method

1. Slowly turn the Phase Lead control from one extreme to the other.

The pressure will oscillate around the set point pressure. The oscillations will be dramatic at first, then decrease to a minimum (and maybe stop) at a particular setting, and then increase again. The optimum phase lead setting produces a minimum amount of oscillation.

2. *If the oscillations persist at the optimum phase lead:* Reduce the gain until the oscillations cease.

The best pressure control occurs with the highest possible gain, so reduce the gain only as much as is necessary to prevent oscillation.

---

### Note



The speed of the pressure response is relative and depends on the process chamber size and absolute pressure. Lower pressures (less than 10 microns) are usually slower because of the slower molecular flow (and reduced pumping speed). In these cases, set the phase lead by *very slowly* moving the Phase Lead control from one extreme to the other.

---

---

## How To Change the Response Switch Setting

In most applications, when the pressure is greater than the set point, the valve should move toward the full Open position to return the pressure to the proper value. This is referred to as the “normal” valve operation and assumes that the output of the pressure transducer increases positively for increasing pressure.

Use the “reverse” mode of operation when:

- The output of the transducer *decreases* for increasing pressure
- The valve is moved from the exhaust line to the input side of the process chamber (upstream control)

---

### Warning



**The 152 controller has lethal voltages inside. Servicing of the unit must be performed by qualified personnel only.**

**To avoid an electrical shock, disconnect the power line *before* opening the unit.**

---

1. Turn off the power to the 152 controller.
2. Disconnect the AC power cord.

---

### Caution



**To avoid damage to sensitive internal components, personnel should be grounded through a safety impedance while working inside the 152 controller, and the unit itself must be static-free.**

---

3. Unscrew the two phillips screws at the rear of the controller and remove the cover.
4. Locate the response switch on the motherboard.  
The response switch is located in the upper right hand portion of the board, when viewed from the front of the controller.
5. Move the switch lever towards the rear panel to select the reverse mode of operation.

## **How To Select a Set Point Value**

- Apply the appropriate voltage to pin 1 on the Interface connector

Refer to Table 3, page 19, for a complete list of pin assignments for the Interface connector. Table 11, page 37, lists the voltage value and its corresponding set point value.

<b>Set Point Voltages</b>	
<b>Applied Voltage (Volts)</b>	<b>Set Point Value (%)</b>
0	0
2.5	50
5	100

Table 11: Applied Voltage and the Corresponding Set Point

## **How To Adjust the Zero**

1. Pump down the system to a pressure less than the resolution of the pressure transducer.  
Refer to your transducer manual to determine the appropriate pressure. This step may take several hours.
2. Adjust the Zero pot, located on the front panel of the 152 controller, to set the zero reading.

## How To Adjust the Span

### Caution



---

**Be sure that your system is configured to withstand the full scale pressure *before* proceeding. Otherwise, your system may be damaged.**

---

1. Adjust the zero.

Follow the steps outlined in the *How To Adjust the Zero* section, on page 37.

2. Apply full scale pressure to the transducer.

Alternately, you can apply 10 Volts to pin 1 on the Input connector, referenced to pin 8. Refer to Table 2, page 18, for the list of pin assignments for the Input connector.

3. Read the pressure output signal.

The pressure output signal is available on pin 2 of the Interface connector, referenced to pin 8.

4. Turn the Span pot, located on the controller front panel, to change the pressure reading.

The pressure output signal should match the pressure input signal.

## Chapter Five

### Remote Zero and Valve Position Output Option

The Remote Zero and Valve Position Output (RZ/VPO) option provides remote zero correction capability and valve position output on a single board. The features can operate separately or simultaneously.

**Note**

---

When the RZ/VPO option is installed, the RZ/VPO board replaces the PC/VPO (Position Control/Valve Position Output) board.

---

### Remote Zero

The Remote Zero (RZ) capability allows you to remotely zero the pressure input signal by  $\pm 2\%$  of the 10 Volt DC range. This zero signal is in addition to the  $\pm 2\%$  capability of the front panel Zero control. The RZ function is accessed through pin 9 on the Interface connector. This line is internally pulled up to +5 Volts with a 4.7K resistor. To initiate the RZ correction, connect pin 9 to the digital ground (pin 3) using either a relay contact closure, TTL, open collector transistor, or 5 V CMOS logic. This connection applies a low signal to the RZ pin.

**Note**

---

During a process cycle, only use the remote zero when the pressure being measured is less than  $\pm 2\%$  of the 10 Volt DC range. Otherwise, the 152 controller will establish an invalid zero.

---

The 152 controller applies the RZ correction *after* the front panel zero correction.

## **How To Use the Remote Zero**

The RZ correction is automatically centered when the 152 controller is turned on.

1. Allow the pressure in the process chamber to thermally stabilize.

This step will take approximately one-half hour for non-heated transducers and four hours for heated transducers.

2. Pump down the process chamber to a pressure less than the resolution of the pressure transducer.

Refer to your transducer manual for the appropriate pressure and an estimate of the time required.

3. Use the front panel Zero control to produce an output of 0.000 volts (pressure) on Interface pin 2 (pressure output).

Whenever the pressure in the process chamber is below the resolution of the pressure transducer, the Zero line (pin 9 on the Interface connector) should be brought low to activate the correction cycle. The correction cycle takes approximately 0.1 seconds. The pressure input signal must not change during that time. The Zero must be low for at least 10 milliseconds and must be high for at least 100 milliseconds before going low.

Refer to Table 3, page 19, for a complete list of the pin assignments for the Interface connector.

4. Read the pressure output signal at pin 2.

The reading should be  $0.000 \pm 0.001$  Volts.

## **The Overrange Output**

The RZ option includes an overrange output, available on pin 11 of the Interface connector. This open collector transistor turns on when the RZ option reaches either the maximum positive or maximum negative correction. When the RZ output reaches either level, the signal output is probably not fully zero corrected. Manually adjust either the transducer or the front panel Zero control.

## **Valve Position Output**

The Valve Position Output (VPO) provides a real-time analog signal at pin 10 of the Interface connector. Refer to Table 3, page 19, for the complete list of pin assignments for the Interface connector. This signal is 0 Volts (0%) when the valve is fully closed and 10 Volts (100%) when the valve is fully opened. Since the volume of gas removed from a vacuum pumping system will be a function of both the valve's position (and therefore, conductance) and the pumping speed, any progressive movement of the valve towards the open position (for the same set point), will indicate a general deterioration in the performance of the pump. You may be able to discern when the pump requires maintenance by observing the position of the valve.

### **How Valve Position Output Works**

When the 152 controller is powered up, the output voltage goes to the position indicated by the valve's limit switches: 0 V for close and 10 V for open. If the valve is not at a limit switch, the Valve Position Output (VPO) is not defined, so the 152 controller cannot track the valve position. At this point, the output voltage will be greater than 10 Volts. When the valve contacts either limit switch, the VPO is defined so the 152 controller can track the valve position with an output voltage between 0 and 10 Volts.

## How To Set the Valve Speed on the RZ/VPO Board

The 152 controller is shipped with the VPO set for either the standard or the fast Type 253 valve, depending upon which valve is ordered with the 152 controller. You can configure the controller to operate the other speed valve by changing several switch positions on the RZ/VPO board.

### Warning



---

**The 152 controller has lethal voltages inside. Servicing of the unit must be performed by qualified personnel only.**

**To avoid an electrical shock, disconnect the power line *before* opening the unit.**

---

1. Turn off the power to the 152 controller.
2. Disconnect the AC power cord.

### Caution



---

**To avoid damage to sensitive internal components, personnel should be grounded through a safety impedance while working inside the 152 controller, and the unit itself must be static-free.**

---

3. Unscrew the two phillips screws at the rear of the controller and remove the cover.
4. Locate the RZ/VPO board.  

The board is positioned on the connector closest to the center of the controller, adjacent to the ribbon cable connector. If the RS-232 option is installed, its board is positioned along the side panel of the controller.
5. Grasp each end of the board and rock it until it loosens. Lift the board up and out of the unit.
6. Locate the dipswitch bank for Switches 1, 2, and 3.

The switches are located on the extreme right-hand side of the board, when viewed from the component side.

7. Set Switch 3 for the correct valve speed.

Refer to Table 12, for a description of the settings for Switch 3.

<b>Valve Speed Switch Settings (S3)</b>		
<b>Dipswitch</b>	<b>Standard</b>	<b>Fast</b>
1	Open	Closed
2	Closed	Open
3	Open	Open
4	Open	Open

Table 12: Switch Configuration for Valve Speed Setting

8. Set Switches 1 and 2 for the correct full scale count value for the valve.

Refer to Table 13 for a description of the switch settings.

<b>Full Scale Count Switch Settings (S1 &amp; S2)</b>			
<b>Dipswitch Pole</b>	<b>Value</b>	<b>Standard</b>	<b>Fast</b>
S1 4	16	C	O
S1 3	32	C	C
S1 2	64	O	O
S1 1	128	O	O
S2 4	256	O	C
S2 3	512	O	O
S2 2	1K	C	C
S2 1	2K	O	C
<i>where C = Closed, O = Open</i>			

Table 13: Switch Configuration for the Valve Full Scale Counts

This page intentionally left blank.

## Chapter Six: RS-232 Communications Option

The RS-232 Interface option allows an external personal computer (PC) to communicate with, and control, the 152 controller. The computer can read in pressure, valve position, set point, and an auxiliary input voltage, along with several digital status lines. The computer can also output set point and digital override commands (Open, Close, Stop, Softstart, Auto, Zero, and Position Control). The digital override commands are issued by grounding selected pins on the Interface connector.

The electrical and mechanical characteristics of the RS-232 interface comply with the 1969 revision of the EIA (Electronic Institute of America) RS-232C specification.

### Note



The mode switch on the front panel must be in the REMOTE position before the 152 controller will recognize any RS-232 communication.

### Initial Communication Parameters

The RS-232 Interface option is shipped with the communication parameters set according to Table 14.

RS-232 Communication Parameters	
Parameter	Setting
Parity	Even
Stop Bit	One
Data Bits	Seven
Baud Rate	9600

Table 14: RS-232 Communication Parameters

## RS-232 Connector

The RS-232 connector is a female 25-pin Type “D” connector.

<b>RS-232 Connector Pin Assignments</b>			
<b>Pin</b>	<b>Assignment</b>	<b>Pin</b>	<b>Assignment</b>
1	Chassis Ground	14	Reserved
2	Transmitted Data	15	Reserved
3	Received Data	16	Reserved
4	Request to Send	17	Reserved
5	Clear to Send	18	Reserved
6	Data Set Ready	19	Reserved
7	Signal Ground	20	Data Terminal Ready
8	Reserved	21	Reserved
9	Reserved	22	Reserved
10	Reserved	23	Reserved
11	Reserved	24	Reserved
12	Reserved	25	Reserved
13	Reserved		

Table 15: RS-232 Connector Pin Assignments

### Note



The RS-232 connector is designed to interface with all status lines, however, it is possible to interface using only pins 1, 2, 3, and 7.

## How To Change the Communication Parameters

### Warning



---

**The 152 controller has lethal voltages inside. Servicing of the unit must be performed by qualified personnel only.**

**To avoid an electrical shock, disconnect the power line *before* opening the unit.**

---

1. Turn off the power to the 152 controller.
2. Disconnect the AC power cord.

### Caution



---

**To avoid damage to sensitive internal components, personnel should be grounded through a safety impedance while working inside the 152 controller, and the unit itself must be static-free.**

---

3. Unscrew the two phillips screws at the rear of the controller and remove the cover.
4. Locate the RS-232 board.  
The board is positioned adjacent to the right side panel, when viewed from the front panel. Either the Position Control/VPO or the Remote Zero/VPO board is installed in the inner slot.
5. Grasp each end of the board and rock it until it loosens. Lift the board up and out of the unit.
6. Locate the Switch 1 dipswitch bank to change the parity, number of stop bits, or the number of data bits.

Switch 1 is located in the upper left-hand portion of the board, when viewed with the component side up.

7. Configure Switch 1 for the new setting(s).

Table 16, page 48 describes the configuration options for Switch 1.

<b>RS-232 Switch 1 Configuration</b>						
<b>Parity</b>	<b>Stop Bits</b>	<b>Data Bits</b>	<b>Pole 1</b>	<b>Pole 2</b>	<b>Pole 3</b>	<b>Pole 4</b>
ODD	1	7	1	1	1	1
ODD	2	7	1	1	0	1
EVEN	1	7	1	0	1	1
EVEN	2	7	1	0	0	1
NONE	1	7	1	X	1	0
NONE	2	7	1	X	0	0
ODD	1	8	0	1	1	1
ODD	2	8	0	1	0	1
EVEN	1	8	0	0	1	1
EVEN	2	8	0	0	0	1
NONE	1	8	0	X	1	0
NONE	2	8	0	X	0	0
<i>where</i> <i>0 = Open (down)</i> <i>1 = Close (up)</i> <i>X = Does not matter</i>						

Table 16: RS-232 Switch 1 Configuration

8. Locate Switch 2 and set the baud rate.

Switch 2 is located adjacent to Switch 1. Refer to Table 17 for the baud rate settings.

<b>RS-232 Switch 2 Configuration</b>				
<b>Baud Rate</b>	<b>Pole 1</b>	<b>Pole 2</b>	<b>Pole 3</b>	<b>Pole 4</b>
300	0	1	0	0
600	1	0	0	1
1200	0	0	1	0
1800	1	0	1	0
2400	0	0	0	1
4800	0	1	1	0
9600	1	1	1	0
<i>where 0 = Open (down)</i> <i>1 = Close (up)</i> <i>X = Does not matter</i>				

Table 17: RS-232 Switch 2 Configuration

## The Internal/External Set Point

The Internal/External Set Point switch, located in the upper front portion of the RS-232 option board, is normally shipped in the Internal position so that the set point will be determined by the RS-232 Interface. Select the External Set Point position if the set point will be determined by an external DC voltage (0 to 5 V). Follow the steps below to change the Internal/External switch setting.

### Warning



**The 152 controller has lethal voltages inside. Servicing of the unit must be performed by qualified personnel only.**

**To avoid an electrical shock, disconnect the power line *before* opening the unit.**

1. Turn off the power to the 152 controller.
2. Disconnect the AC power cord.

### Caution



**To avoid damage to sensitive internal components, personnel should be grounded through a safety impedance while working inside the 152 controller, and the unit itself must be static-free.**

3. Unscrew the two phillips screws at the rear of the controller and remove the cover.
4. Locate the RS-232 Interface board.  
The board is positioned adjacent to the right side panel, when viewed from the front panel. Either the Position Control/VPO or the Remote Zero/VPO board is installed in the inner slot.
5. Grasp each end of the board and rock it until it loosens. Lift the board up and out of the unit.
6. Locate the Internal/External switch and change its position.  
Switch 4 is located in the upper right-hand portion of the board, when viewed with the component side up.

## **Operation**

After power up, the RS-232 Interface is passive until the 152 controller receives an external command through the serial port.

### **Wake-Up**

When the 152 controller is powered up, the RS-232 Interface is initialized with the set point at 0% and no digital lines activated. This sets the 152 controller for automatic operation at 0% pressure.

Upon power up, it takes approximately 1.5 seconds for the 152 controller to stabilize and the RS-232 Interface to initialize. Therefore, you should not send any commands to the controller for approximately 2 seconds after power up.

## RS-232 Commands

The RS-232 commands can change specific operating parameters or request that the 152 controller report specific information. Commands can be followed by a carriage return line feed (CRLF), or just a line feed (LF). Commands can be issued in either upper or lower case letters.

### Instruction Commands

Instruction commands cover signals sent from the computer to the 152 controller. These signals include commands to change the set point, report data, and override the set point. The instruction commands are listed in Table 18.

RS-232 Instruction Commands	
Purpose	Command
Change the Internal Set Point	S1DD.D<CR LF> where DD.D = Set Point value, as % of Full Scale (0 to 100)
Report Data	RY<CR LF> where Y can be: 0 = Auxiliary 1 = Set Point 1 5 = Pressure Input 6 = Position of Valve 7 = Status Request
Digital Command to Override Set Point	X<CR LF> where X can be: O = Open Valve C = Close Valve H = Stop (Halt) Valve S = Softstart initiate D = Auto (cancels valve commands)* Z = Zero Pressure Input** P = Position Control †
<p>* Valve commands (Open, Close, Stop, and Position Control) remain ON until canceled by the "D" Auto command</p> <p>** Requires the Remote Zero/Valve Position Output option</p> <p>† Requires the standard Position Control/Valve Position Output configuration</p>	

Table 18: RS-232 Instruction Commands

### Set Point Instructions

The 152 controller expects to see the set point instruction, sent from the computer, issued in the following fashion: 2 or 3 digits of data, followed by a decimal point and another digit of data. However, it will accept alternate versions. For example, a set point of 1% can be issued as:

01.0

001

1

1.0

---

**Note**

If the command does not include a value (S1<CR LF>), the 152 controller enters 0% as the new set point value.

---

### Valve Commands

The valve commands, Open, Close, and Stop (Halt), will override any drive signals initiated by the set point control and command the valve to the open, close, or stop position. Only one command can be executed at a time. Each command, once initiated, will remain effective until:

- The “D” or Auto command is issued
- The “P” or Position Control command is issued
- One of the other valve commands (Open, Close, Stop (Halt)) is issued
- The power is lost

### Softstart Command

When the softstart command (“S”) is issued, the 152 controller will slowly drive toward the correct pressure. Once the 152 controller establishes the correct pressure, it returns to full speed operation. The softstart command is self-canceling since the “D” or Auto command, does not have to be issued to return to Automatic operation. Since the Open, Close, and Halt (Stop) commands negate any softstart command, the 152 controller must be in AUTO operation *before* the Softstart command is issued.

### Zero Command

---

**Note**

Be sure that the pressure of the process chamber is less than the resolution of the pressure transducer *before* you issue the Zero command. Otherwise, the 152 controller will establish an invalid zero.

---

This command requires the Remote Zero/Valve Position Output (RZ/VPO) optional board. The Zero command (“Z”) enables a remote instrument to adjust the zero reading on the 152 controller. Once the command is sent, it does not need to be canceled.

### Data Sent From the 152 Controller to the Computer

The 152 controller sends information to the computer upon request. This information includes the status of several parameters, and a status report of the valve position. Refer to Table 19 for a list of the messages transmitted from the 152 controller.

<b>Data Sent From the 152 Controller</b>	
<b>Purpose</b>	<b>Command</b>
Reports Analog Signal Level	XDDD.D<CR LF> where X can be: S = Set Point (-1 to 101%) P = Pressure (-1 to 101%) V = Valve Position (0 to 90°) A = Auxiliary Input (-1 to 101%) E = Error  DDD.D is data (in % or degrees)
STATUS Reply	MXYZ<CR LF> where M is Mode X is Set Point in Use: 0 = External 1 = Internal  Y is the Valve Drive Status H = Holding (Stopped) O = Opening C = Closing A = Automatic (Pressure Control) D = Delayed (softstart) P = Position Control†  and Z is the Control Status 0 = In Control 3 = At Open L.S. 4 = At Close L.S.
** Requires the Remote Zero/Valve Position Output option † Requires the standard Position Control/Valve Position Output configuration	

Table 19: Data Sent From the 152 Controller

**Errors**

The 152 controller will return an “E” (for Error) if it does not understand a command. The error is usually either a syntax or transmission error.

**RS-232 Buffer Size**

The internal input command buffer can store 40 characters. The Data Terminal Ready (DTR) line will become inactive when this input buffer is within ten characters of being filled.

This page intentionally left blank.

## Appendix A: Product Specifications

Input Signal	0 to 10 VDC 0 to 1 VDC, selectable on the rear panel and via an external command
Output Signal	0 to 10 VDC (10K min. load) <i>Zero corrected</i>
Input Power  VDE Approved Connectors	90 to 132 VAC @ 50/60 Hz or 180 to 264 VAC @ 50/60 Hz 60 Watts maximum Power Switch, Voltage Selection Switch, Fuse Holder, and AC Input Connector
External Set Point Signal	0 to 5 VDC analog (> 1 Meg ohm input impedance)
External Input Commands  Action	TTL compatible (5V, 4.7K pull-up) Input activated by a LO signal (< 1 Volt) Close Open Stop Softstart Position Control 1 VDC Full Scale Input
Regulation	±0.1% of full scale
Temperature	0 to 40° C (32 to 104° F)
Output Power	±15 ±0.2 VDC @ 250 mA maximum
Valve Output	Built in driver to power the Type 253 exhaust valve (24 Volts @ 1 Amp maximum)

Dimensions	3½”H x 9½”W x 9½”L (8.9 cm x 24.1 cm x 24.1 cm)
Fuses	
90 - 132 VAC	0.6A Slo Blo 250 V, 5 x 20 mm
180 - 264 VAC	0.3A Slo Blo 250 V, 5 x 20 mm

Due to continuing research and development activities, these product specifications are subject to change without notice.

## Index

### 1

10V/1V Selector switch, 21

### A

AC power connector, 20

### C

Companion products, 8

Configuring, 10

    initially, 14

Connections, 11

Customer support, 6

### D

Differential inputs, connecting, 18

Diffusion pumps, using, 10

### E

Error indicator bar, 16

External commands, 28–30

External set point, connecting, 20

### F

Fast Type 253 valve, 25–27, 42–43

Front panel, 15

Fuse information, 22

### G

Gain control, 22

### H

High accuracy, requirements, 13

### I

Input connector, 18

Input range, changing, 30

Interface connector, 19

Internal/External set point, 50

Introduction, 3–4

### M

Manual

    organization, 5

    terminology, 5

Manual control, 33

Messages, definitions of, 2

Mode Switch, 15

### P

Phase Lead control, 22

PID control, 4

Position control, 23–24, 30

Position Control/Valve Position Output, 3, 23–27

Power requirements, 9

Power switch, 16

Pressure rate of rise, calculating, 31

Pressure readout, 12

Pressure transducers, recommended, 12

Product location and requirements, 9

### R

Rear panel controls, 17

Remote Zero/Valve Position Output, 3, 39–44

Response setting, changing, 36

Returning the product, 6, 7

RS-232 communication

    changing parameters, 49

    commands, 52–55

    default parameters, 45

    operation, 51

## **S**

Safety procedures and precautions, 1–2

Softstart mode, 29

Specifications, 57

Standard Type 253 valve, 25–27, 42–43

## **T**

Temperature, operating, 9

Tuning the control loop, 34–35

Type 253 valve

    fast, 25–27, 42–43

    standard, 25–27, 42–43

## **U**

Unpacking checklist, 7

## **V**

Valve connector, 21

Valve Position Output, 25–27, 41

Valve speed, 25–27, 25–27, 42–43, 42–43

Voltage selector, 20

## **Z**

Zero potentiometer, 16

Zero, adjusting, 37